

PARTS CATALOGUE

XJR1300 (5WM1,5WM3) EUROPE,S.AFRICA

XJR1300R (5WM5,5WM6) AUSTRALIA

XJR1300/XJR1300R
PARTS CATALOGUE
E 2002 by Yamaha Motor Co., Ltd.
1st Edition, September 2002
All rights reserved.
Any reprinting or unauthorized use
without the written permission of
Yamaha Motor Co., Ltd.
is expressly prohibited.
Printed in Japan



A4

FOREWORD

This Parts Catalogue is related to the parts for the model(s) in the below frame. When you are ordering replacement parts, please refer to this Parts Catalogue and quote both part numbers and part names correctly.

XJR1300/XJR1300R(5WM1,5WM3/5WM5,5WM6)

1. Modifications or additions which have been made after issue of the Parts Catalogue will be announced in the Yamaha Parts News.
It is advisable that you make necessary corrections to the Parts Catalogue according to the Yamaha Parts News.

2. Abbreviations
The Following abbreviations are used in this Parts Catalogue.

“UR” Use specified parts number.

“UN” Use as many as needed.

“AP” Alternate Parts

“LM” Local Made (Parts need to be ordered locally)

“F#” Frame No. (Applicable machine No.)

3. Parts, which are to be supplied in an assembly, are listed with a dot(.) in front of the part name as shown below.

EXAMPLE

CARBURETOR ASSY

.JET, PILOT

.NOZZLE, MAIN

4. Number of component for assembly
The numeral appearing to the right of each component part indicates the quantity of parts for each assembly unit.

EXAMPLE

PART NO.	DESCRIPTION	Q'TY	REMARKS
2F5-83310-60	FRONT FLASHER LIGHT ASSY	2	
115-83311-60	.BULB (6V-18W)	1	
1M1-83309-60	.REFLECTOR	1	

5. Applicable colors of graphics are represented in the “REMARKS” as shown below.

PART NO.	DESCRIPTION	Q'TY	REMARKS
2N4-24110-00-X5	.FUEL TANK COMP.	2	MXR
3J1-24240-10	.GRAPHIC, FUEL TANK	1	for MXR

6. Applicable Serial No.

Engine Serial No.

Frame Serial No.

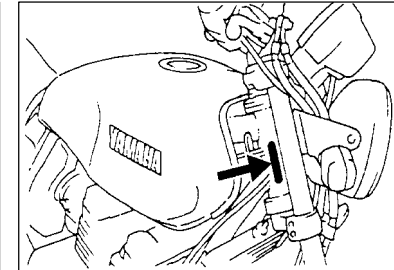
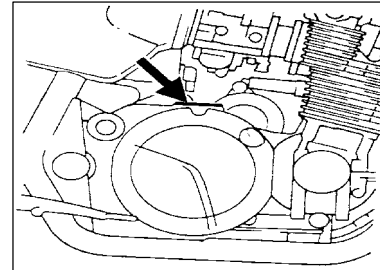

7. Note that the illustrations for reference in finding parts numbers, not to be used for assembling. When assembling, please use the applicable service manual.

8. The asterisk (*) before a reference number indicates modification items after the first edition.

MODEL LABEL

(1) A label called "Model Label" is affixed in the location as indicated in (3) below.
When using this parts catalogue, please be sure to cross-refer the "model code – production code No." in the catalogue to the "model code – production code No." indicated on the Model Label affixed onto the product concerned.

(2) "Model Label" Indication

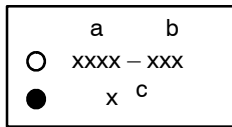

a: Model Type Code
b: Production Code No.
c: Colouring Type

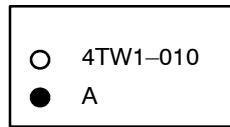

(3) Model Label Affixing Location

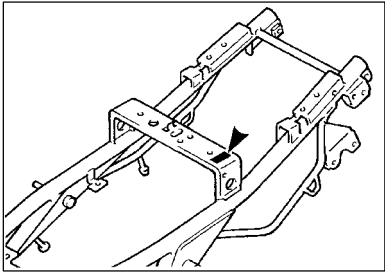

(4) Model Code – Production Code Number of Model Listed in This Parts Catalog

Model Code	Production Code No.	Country (destination)	Model Code	Production Code No.	Country (destination)
5WM1 5WM3	020	BELGIUM			
	030	DENMARK			
		NORWAY			
	040	SPAIN			
	050	ENGLAND			
	060	GREECE			
	070	ITALY			
	080	HOLLAND			
	090	PORTUGAL			
100	SWEDEN				
110	S.AFRICA				
5WM5 5WM6	010	AUSTRALIA			

(5) Colouring Information

Model Code	Colouring type code	Colour code	Colour Name	Abbreviation
5WM1	A	004B	BLACK 2	BL2
5WM5	B	0564	DEEP PURPLISH BLUE METALLIC C	DPBMC
5WM3 5WM6	A	0251	REDDISH YELLOW COCKTAIL 1	RYC1

FIG. 1 CYLINDER HEAD

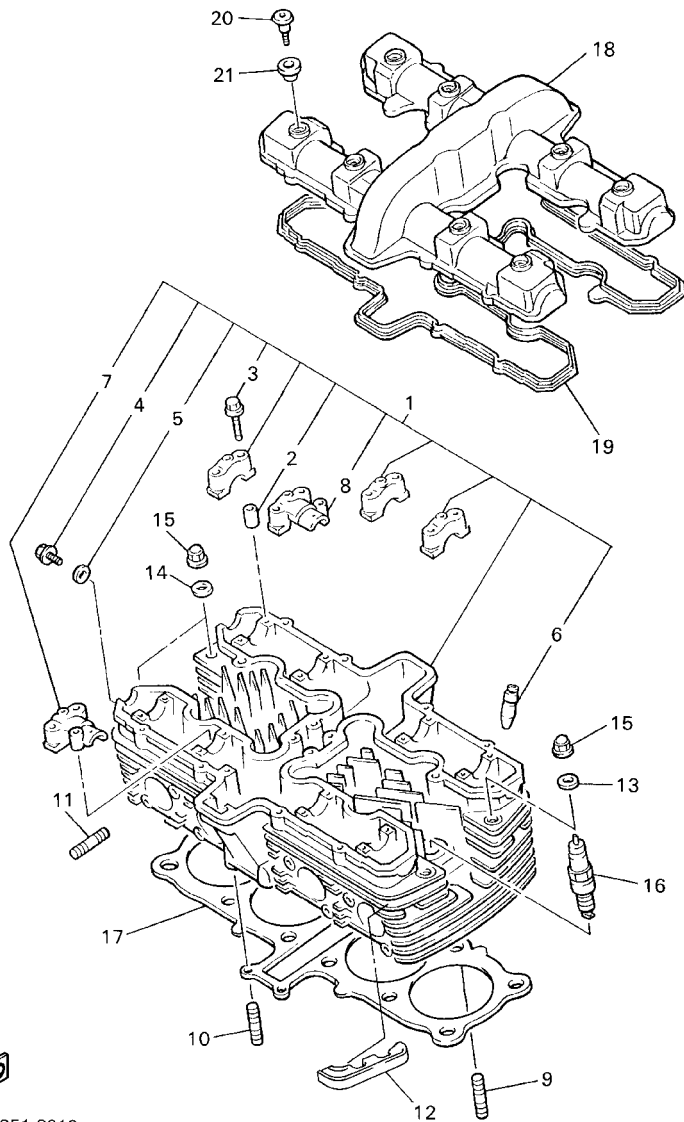

5EAT351-2010

REF. NO.	PART NO.	DESCRIPTION	5WM1	5WM3	5WM5	5WM6	REMARKS
1	5EA-11101-10	CYLINDER HEAD ASSY	1		1		
	5EA-11101-20	CYLINDER HEAD ASSY		1		1	
2	91808-16023	.PIN, DOWEL	16	16	16	16	
3	90105-06305	.BOLT, FLANGE	18	18	18	18	
4	90153-06029	.SCREW, HEXAGON	1	1	1	1	
5	90430-06014	.GASKET	1	1	1	1	
6	36Y-11133-10	.GUIDE, INTAKE VALVE	16	16	16	16	
7	36Y-12193-10	.CAP, CAMSHAFT 3	1	1	1	1	
8	36Y-12178-10	.CAP, CAMSHAFT 4	1	1	1	1	
9	95617-06625	BOLT, STUD	2	2	2	2	
10	95617-06635	BOLT, STUD	2	2	2	2	
11	95617-08625	BOLT, STUD	8	8	8	8	
12	5EA-11161-00	ABSORBER 1	2	2			
13	90201-102G9	WASHER, PLATE	10	10	10	10	
14	90201-10128	WASHER, PLATE	2	2	2	2	
15	90176-10078	NUT, CROWN	12	12	12	12	
16	94701-00241	PLUG, SPARK (NGK DPR8EA-9)	4	4	4	4	
17	5EA-11181-10	GASKET, CYLINDER HEAD 1	1	1	1	1	
18	4KG-11191-10	COVER, CYLINDER HEAD 1	1	1	1	1	
19	5EA-11193-00	GASKET, HEAD COVER 1	1	1	1	1	
20	90109-066F0	BOLT	8	8	8	8	
21	5EA-1111G-00	RUBBER, MOUNT 1	8	8	8	8	

FIG. 2 CYLINDER

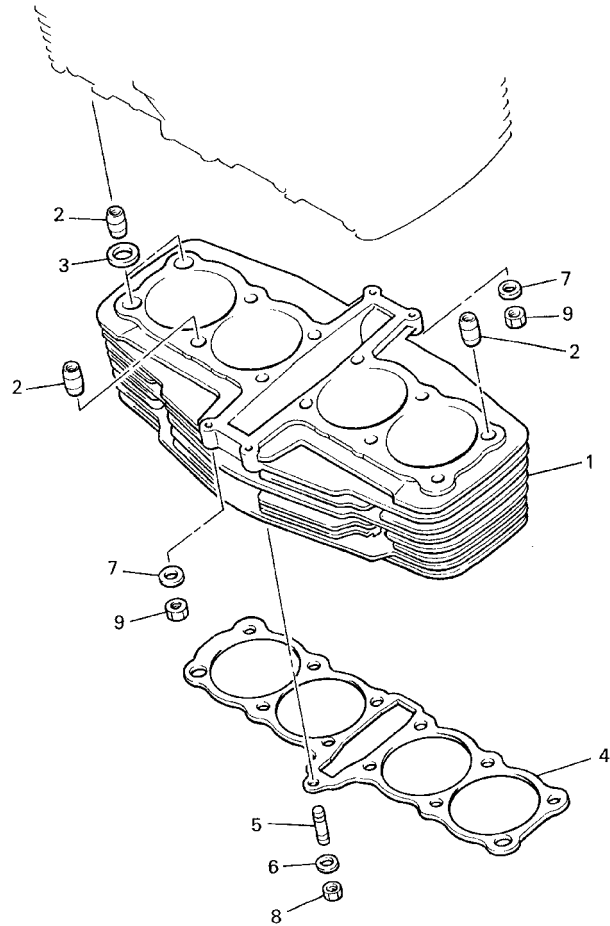

REF. NO.	PART NO.	DESCRIPTION	5WM1	5WM3	5WM5	5WM6	REMARKS
1	5EA-11311-00	CYLINDER 1	1		1		
	5EA-11311-10	CYLINDER 1		1		1	
2	99530-14016	PIN, DOWEL	4	4	4	4	
3	90430-14240	GASKET	2	2	2	2	
4	5EA-11351-00	GASKET, CYLINDER	1	1	1	1	
5	95627-08330	BOLT, STUD	1	1	1	1	
6	90201-08382	WASHER, PLATE	1	1	1	1	
7	92907-06600	WASHER, PLATE	4	4	4	4	
8	95317-08600	NUT	1	1	1	1	
9	95317-06600	NUT	4	4	4	4	



5EA1010-8020

FIG. 3 CRANKSHAFT. PISTON

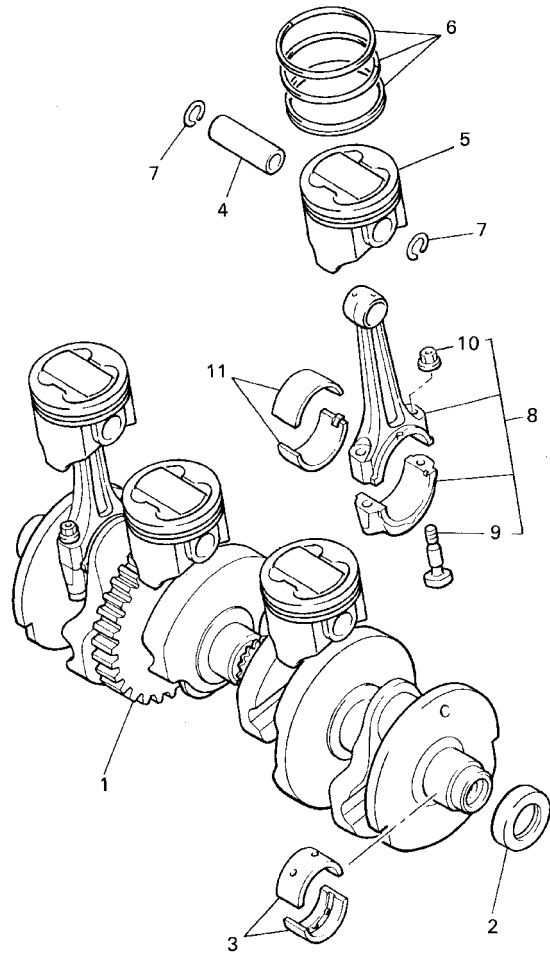

REF. NO.	PART NO.	DESCRIPTION	5WM1	5WM3	5WM5	5WM6	REMARKS
1	36Y-11411-01	CRANKSHAFT	1	1	1	1	
2	36Y-15389-09	OIL SEAL	1	1	1	1	
3	2H7-11416-01	PLANE BEARING, CRANKSHAFT 1	10	10	10	10	UR BLUE
	2H7-11416-11	PLANE BEARING, CRANKSHAFT 1	10	10	10	10	UR BLACK
	2H7-11416-21	PLANE BEARING, CRANKSHAFT 1	10	10	10	10	UR BROWN
	2H7-11416-31	PLANE BEARING, CRANKSHAFT 1	10	10	10	10	UR GREEN
	2H7-11416-41	PLANE BEARING, CRANKSHAFT 1	10	10	10	10	UR YELLOW
4	30X-11633-03	PIN, PISTON	4	4	4	4	
5	5EA-11631-10	PISTON (STD)	4	4	4	4	
6	5EA-11603-00	PISTON RING SET (STD)	4	4	4	4	
7	93450-19052	CIRCLIP	8	8	8	8	
8	5EA-11650-00	CONNECTING ROD ASSY	4	4	4	4	
9	36Y-11654-00	.BOLT, CONNECTING ROD	2	2	2	2	
10	90179-08327	.NUT	2	2	2	2	
11	36Y-11656-00	PLANE BEARING, CONNECTING ROD	8	8	8	8	UR PINK
	36Y-11656-10	PLANE BEARING, CONNECTING ROD	8	8	8	8	UR BLUE
	36Y-11656-20	PLANE BEARING, CONNECTING ROD	8	8	8	8	UR BLACK
	36Y-11656-30	PLANE BEARING, CONNECTING ROD	8	8	8	8	UR BROWN



5EA1010-8030

FIG. 4 VALVE

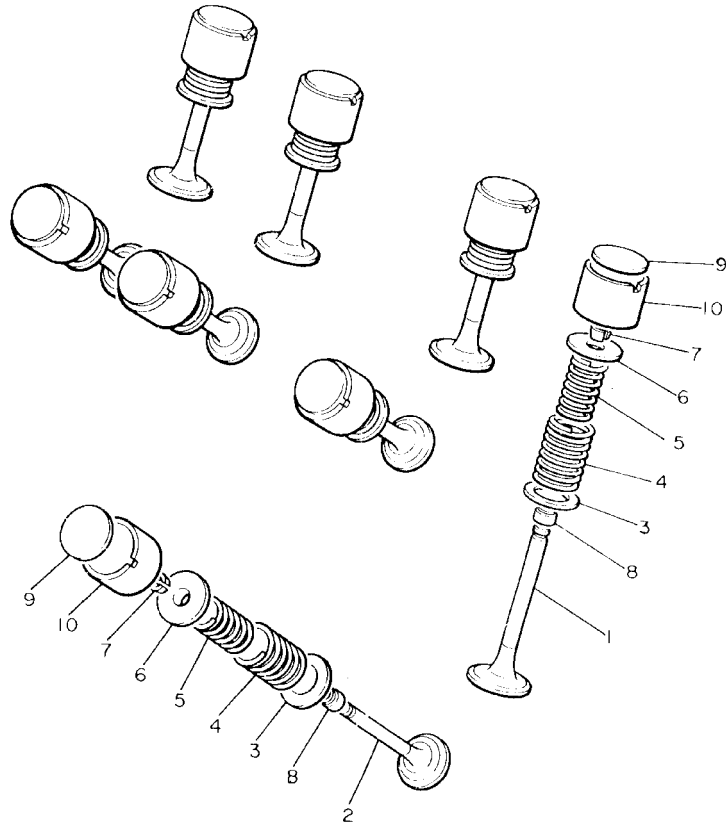

REF. NO.	PART NO.	DESCRIPTION	5WM1	5WM3	5WM5	5WM6	REMARKS
1	36Y-12111-00	VALVE, INTAKE	8	8	8	8	
2	36Y-12121-00	VALVE, EXHAUST	8	8	8	8	
3	26H-12116-00	SEAT, VALVE SPRING	16	16	16	16	
4	36Y-12114-00	SPRING, VALVE OUTER	16	16	16	16	
5	36Y-12113-00	SPRING, VALVE INNER	16	16	16	16	
6	30X-12117-00	RETAINER, VALVE SPRING	16	16	16	16	
7	30X-12118-00	COTTER, VALVE	32	32	32	32	
8	51Y-12119-00	SEAL, VALVE STEM	16	16	16	16	
9	26H-12168-00	PAD, ADJUSTING (2.00)	16	16	16	16	UR
	26H-12168-20	PAD, ADJUSTING (2.05)	16	16	16	16	UR
	26H-12168-40	PAD, ADJUSTING (2.10)	16	16	16	16	UR
	26H-12168-60	PAD, ADJUSTING (2.15)	16	16	16	16	UR
	26H-12168-80	PAD, ADJUSTING (2.20)	16	16	16	16	UR
	26H-12168-A0	PAD, ADJUSTING (2.25)	16	16	16	16	UR
	26H-12168-F0	PAD, ADJUSTING (2.30)	16	16	16	16	UR
	26H-12168-H0	PAD, ADJUSTING (2.35)	16	16	16	16	UR
	26H-12168-K0	PAD, ADJUSTING (2.40)	16	16	16	16	UR
	26H-12168-M0	PAD, ADJUSTING (2.45)	16	16	16	16	UR
	26H-12168-R0	PAD, ADJUSTING (2.50)	16	16	16	16	UR
	26H-12168-U0	PAD, ADJUSTING (2.55)	16	16	16	16	UR
	26H-12168-W0	PAD, ADJUSTING (2.60)	16	16	16	16	UR
	26H-12168-Y0	PAD, ADJUSTING (2.65)	16	16	16	16	UR
	26H-12169-10	PAD, ADJUSTING (2.70)	16	16	16	16	UR
	26H-12169-30	PAD, ADJUSTING (2.75)	16	16	16	16	UR
	26H-12169-50	PAD, ADJUSTING (2.80)	16	16	16	16	UR
	26H-12169-70	PAD, ADJUSTING (2.85)	16	16	16	16	UR
	26H-12169-90	PAD, ADJUSTING (2.90)	16	16	16	16	UR

4H7110-0050

FIG. 5 CAMSHAFT. CHAIN

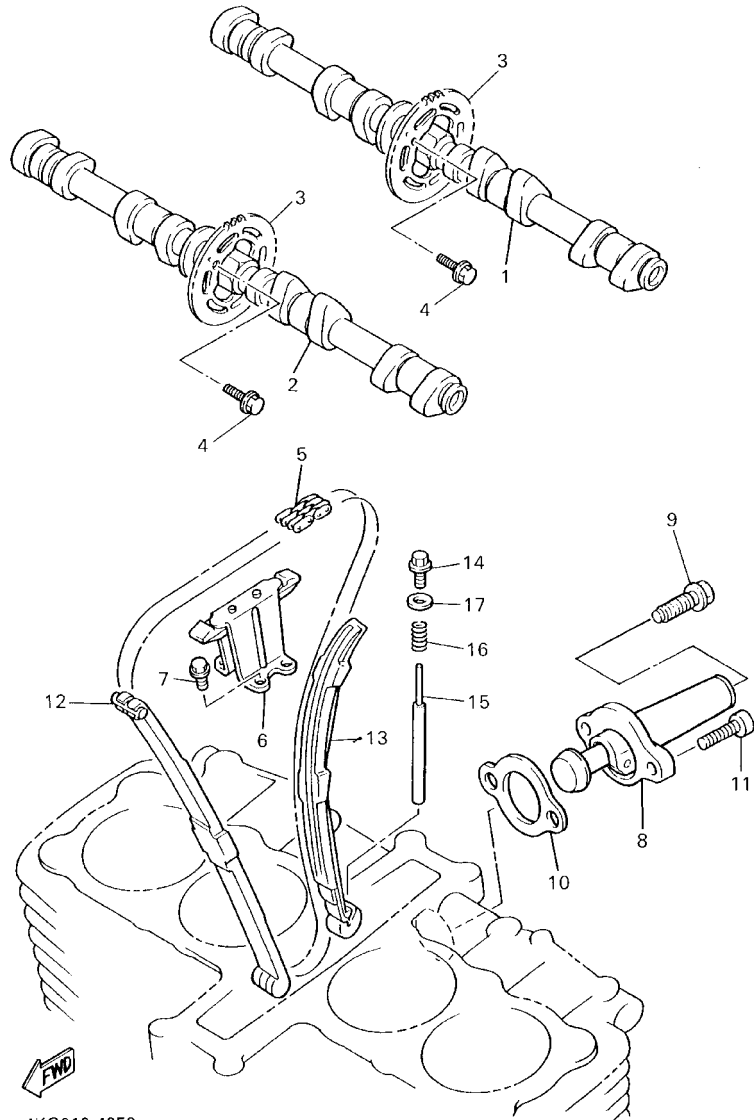

4KG010-4050

REF. NO.	PART NO.	DESCRIPTION	5WM1	5WM3	5WM5	5WM6	REMARKS
1	5EA-12171-00	CAMSHAFT 1	1	1	1	1	
2	5EA-12181-00	CAMSHAFT 2	1	1	1	1	
3	36Y-12176-00	SPROCKET, CAM CHAIN	2	2	2	2	
4	90105-07342	BOLT, FLANGE	4	4	4	4	
5	94591-05156	CHAIN	1	1	1	1	
6	5EA-12241-00	GUIDE, STOPPER 2	1	1	1	1	
7	90105-06424	BOLT, FLANGE	4	4	4	4	
8	4KG-12210-00	TENSIONER ASSY, CAM CHAIN	1	1	1	1	
9	4KG-12222-00	PLUG	1	1	1	1	
10	4FM-12213-00	GASKET, TENSIONER CASE	1	1	1	1	
11	91317-06025	BOLT	2	2	2	2	
12	36Y-12251-00	DAMPER, CHAIN 1	1	1	1	1	
13	36Y-12252-03	DAMPER, CHAIN 2	1	1	1	1	
14	90340-10108	PLUG, STRAIGHT SCREW	1	1	1	1	
15	90249-04184	PIN	1	1	1	1	
16	90501-153A2	SPRING, COMPRESSION	1	1	1	1	
17	90201-10118	WASHER, PLATE	1	1	1	1	

FIG. 6 OIL PUMP

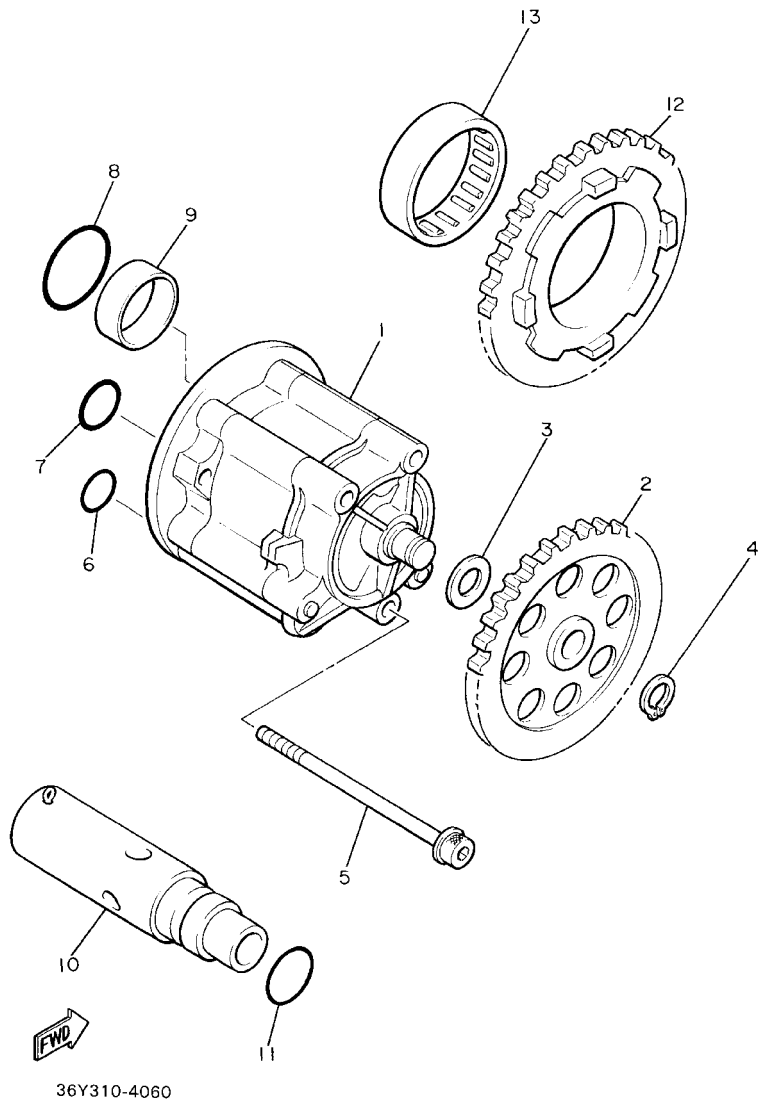

REF. NO.	PART NO.	DESCRIPTION	5WM1	5WM3	5WM5	5WM6	REMARKS
1	3CV-13300-00	OIL PUMP ASSY	1	1	1	1	
2	36Y-13325-00	GEAR, PUMP DRIVEN (32T)	1	1	1	1	
3	90201-102M1	WASHER, PLATE	1	1	1	1	
4	93440-09139	CIRCLIP	1	1	1	1	
5	95817-06080	BOLT, FLANGE	3	3	3	3	
6	93210-13657	O-RING	1	1	1	1	
7	93210-15566	O-RING	1	1	1	1	
8	93210-26658	O-RING	1	1	1	1	
9	93626-08210	PIN, DOWEL	1	1	1	1	
10	36Y-13490-00	RELIEF VALVE ASSY	1	1	1	1	
11	93210-15566	O-RING	1	1	1	1	
12	36Y-13324-00	GEAR, PUMP DRIVE (36T)	1	1	1	1	
13	93315-23607	BEARING	1	1	1	1	

FIG. 7 OIL COOLER

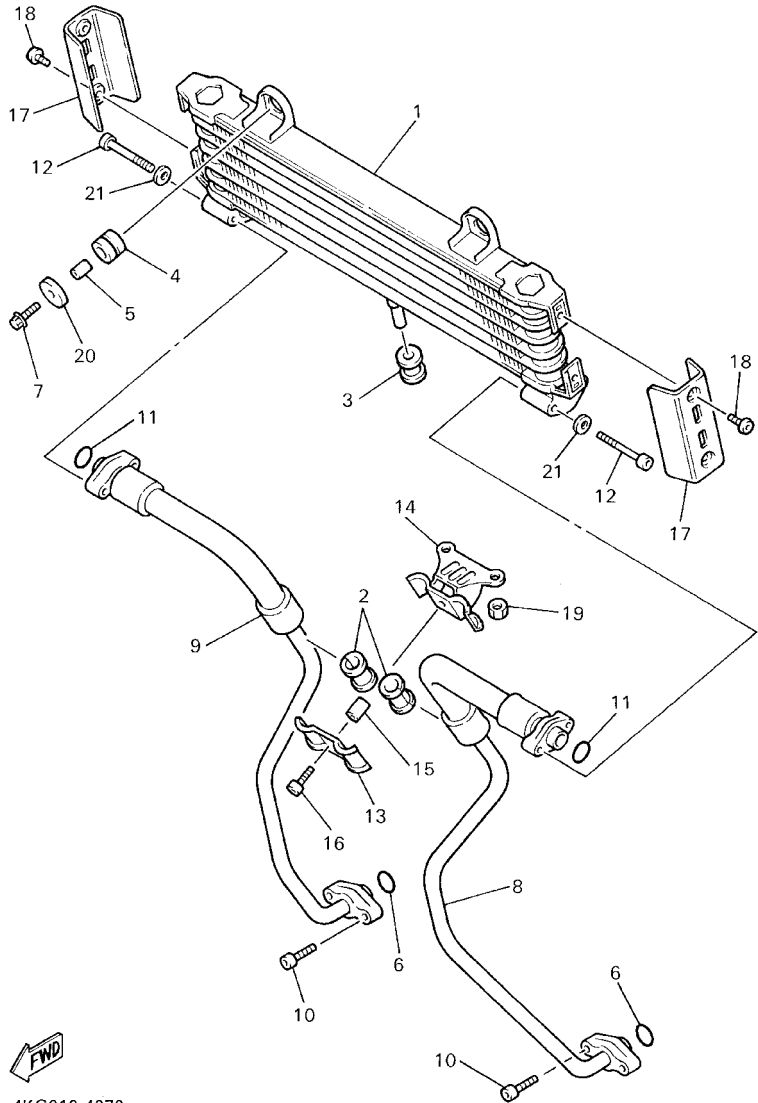

4KG010-4070

REF. NO.	PART NO.	DESCRIPTION	5WM1	5WM3	5WM5	5WM6	REMARKS
1	4KG-13470-10	OIL COOLER ASSY	1	1	1	1	
2	4KG-13159-00	DAMPER	2	2	2	2	
3	90480-16284	GROMMET	1	1	1	1	
4	90480-15235	GROMMET	2	2	2	2	
5	90387-060A7	COLLAR	2	2	2	2	
6	93210-13657	O-RING	2	2	2	2	
7	95827-06020	BOLT, FLANGE	2	2	2	2	
8	4KG-13464-10	HOSE, OIL 1	1	1	1	1	
9	4KG-13465-10	HOSE, OIL 2	1	1	1	1	
10	91317-06020	BOLT	4	4	4	4	
11	93210-16325	O-RING	2	2	2	2	
12	91317-06040	BOLT	4	4	4	4	
13	4KG-13151-00	STAY	1	1	1	1	
14	4KG-13152-01	STAY 2	1	1	1	1	
15	90387-064M9	COLLAR	1	1	1	1	
16	91317-06020	BOLT	1	1	1	1	
17	4HM-13463-00	COVER, OIL COOLER	2	2	2	2	
18	92014-06012	BOLT, BUTTON HEAD	4	4	4	4	
19	95317-06600	NUT	2	2	2	2	
20	90209-06174	WASHER	2	2	2	2	
21	92907-06200	WASHER	4	4	4	4	

FIG. 8 OIL CLEANER

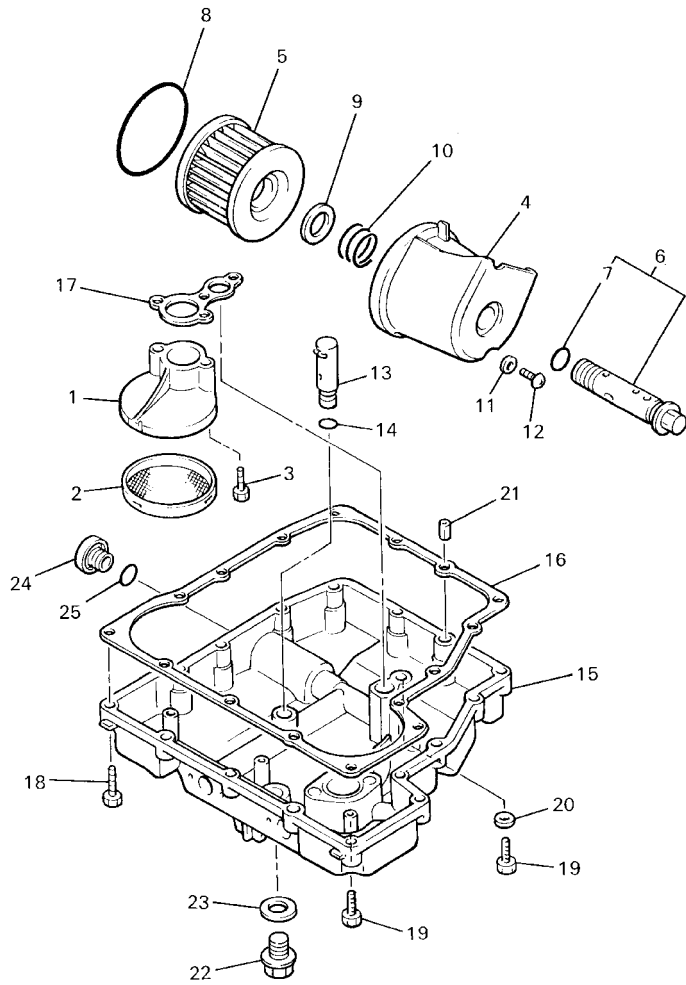

4PU9351-8080

REF. NO.	PART NO.	DESCRIPTION	5WM1	5WM3	5WM5	5WM6	REMARKS
1	36Y-13412-00	HOUSING, STRAINER	1	1	1	1	
2	4H7-13411-02	STRAINER, OIL	1	1	1	1	
3	91317-06020	BOLT	2	2	2	2	
4	5EA-13447-00 4KG-13447-00	COVER, OIL ELEMENT COVER, OIL ELEMENT	1		1	1	
5	36Y-13441-00	ELEMENT, OIL CLEANER	1	1	1	1	
6	36Y-13340-00	BY-PASS VALVE ASSY	1	1	1	1	
7	93210-16325	O-RING	1	1	1	1	
8	93210-87723	O-RING	1	1	1	1	
9	90201-21608	WASHER, PLATE	1	1	1	1	
10	90501-20422	SPRING, COMPRESSION	1	1	1	1	
11	90430-05126	GASKET	1	1	1	1	
12	90149-05110	SCREW	1	1	1	1	
13	25G-13490-00	RELIEF VALVE ASSY	1	1	1	1	
14	93210-10096	O-RING	1	1	1	1	
15	36Y-13417-02	COVER, STRAINER	1	1	1	1	
16	4CR-13414-00	GASKET, STRAINER COVER	1	1	1	1	
17	4CR-13415-00	SEAL, OIL STRAINER	1	1	1	1	
18	91317-06025	BOLT	14	14	14	14	
19	91317-06035	BOLT	3	3	3	3	
20	90430-06014	GASKET	1	1	1	1	
21	99530-08016	PIN, DOWEL	2	2	2	2	
22	90340-14132	PLUG, STRAIGHT SCREW	1	1	1	1	
23	214-11198-01	GASKET	1	1	1	1	
24	36Y-15189-00	PLUG	1	1	1	1	
25	93210-16325	O-RING	1	1	1	1	

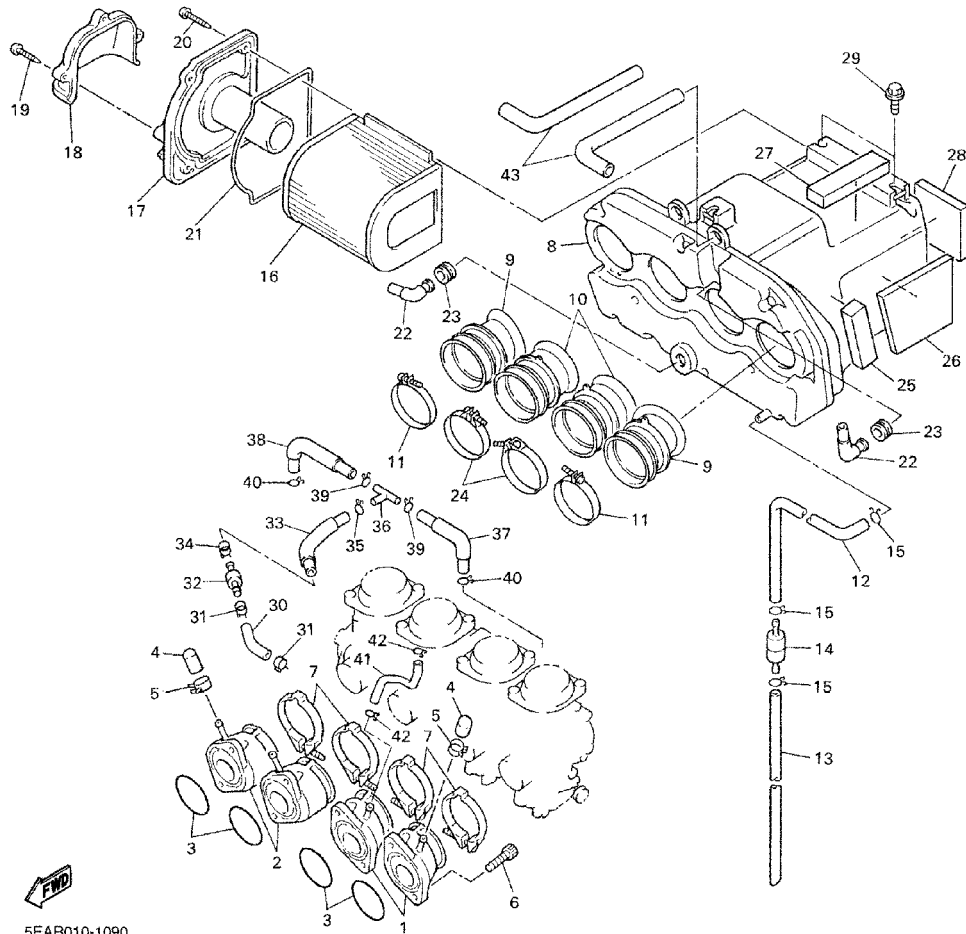

FIG. 9 INTAKE

REF. NO.	PART NO.	DESCRIPTION	5WM1	5WM3	5WM5	5WM6	REMARKS
1	5EA-13586-10	JOINT, CARBURETOR 1	2	2	2	2	
2	5EA-13596-10	JOINT, CARBURETOR 2	2	2	2	2	
3	93210-40659	O-RING	4	4	4	4	
4	16G-13569-00	PLUG, BLIND	2	2	2	2	
5	90467-10039	CLIP	2	2	2	2	
6	91317-06020	BOLT	8	8	8	8	
7	5EL-13474-00	BAND	4	4	4	4	
8	5EA-14401-00	AIR CLEANER CASE ASSY	1	1	1	1	
9	5EA-14453-00	JOINT, AIR CLEANER 1	2	2	2	2	
10	5EA-14463-00	JOINT, AIR CLEANER 2	2	2	2	2	
11	90450-64001	HOSE CLAMP ASSY	2	2	2	2	
12	1HX-1443E-00	PIPE, DRAIN	1	1	1	1	
13	90445-115K8	HOSE (L370)	1	1	1	1	
14	4X7-2149Y-00	FILTER ASSY	1	1	1	1	
15	90467-11106	CLIP	3	3	3	3	
16	4KG-14451-00	ELEMENT, AIR CLEANER	1	1	1	1	
17	5EA-14412-00	CAP, CLEANER CASE 1	1	1	1	1	
18	4KG-14437-00	DUCT	1	1	1	1	
19	97707-50125	SCREW, TAPPING	3	3	3	3	
20	97707-50125	SCREW, TAPPING	4	4	4	4	
21	3LD-14462-00	SEAL	1	1	1	1	
22	31A-14419-00	PIPE	2	2	2	2	
23	31A-14435-00	GROMMET	2	2	2	2	
24	90450-63002	HOSE CLAMP ASSY	2	2	2	2	
25	5EA-14425-00	DAMPER 1	1	1	1	1	
26	5EA-14426-00	DAMPER 2	1	1	1	1	
27	5EA-1442G-00	DAMPER 3	1	1	1	1	

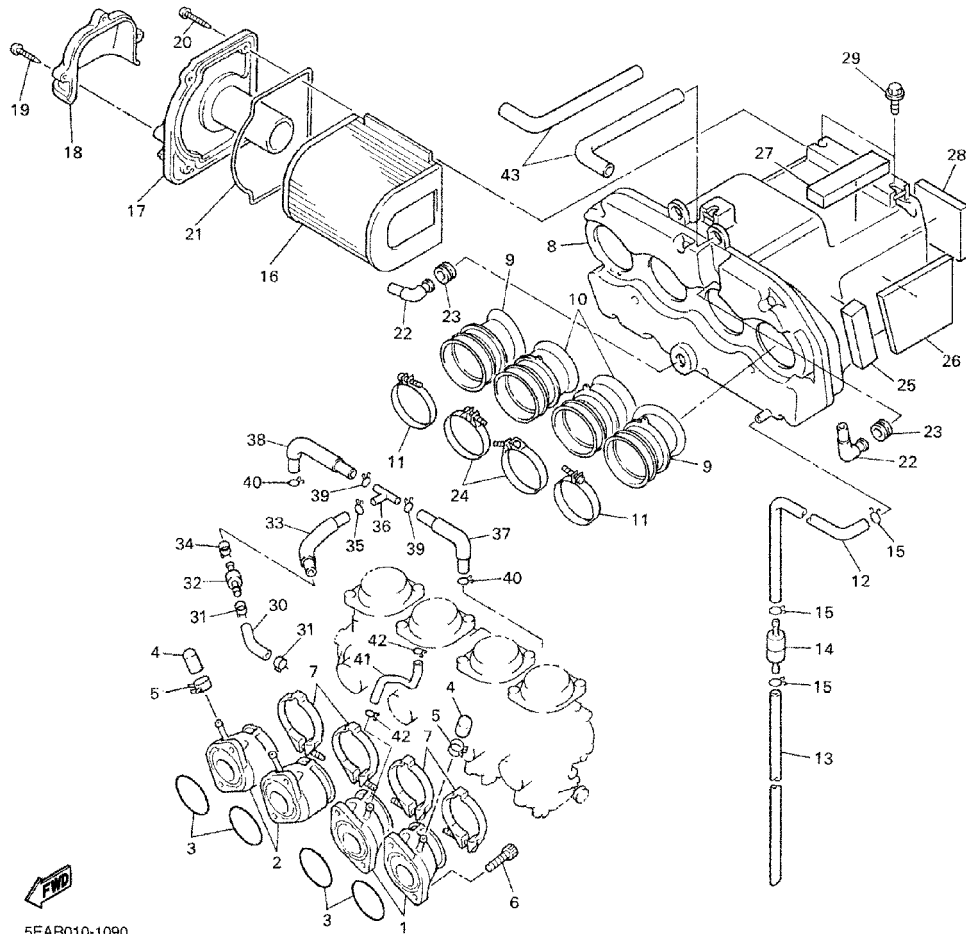
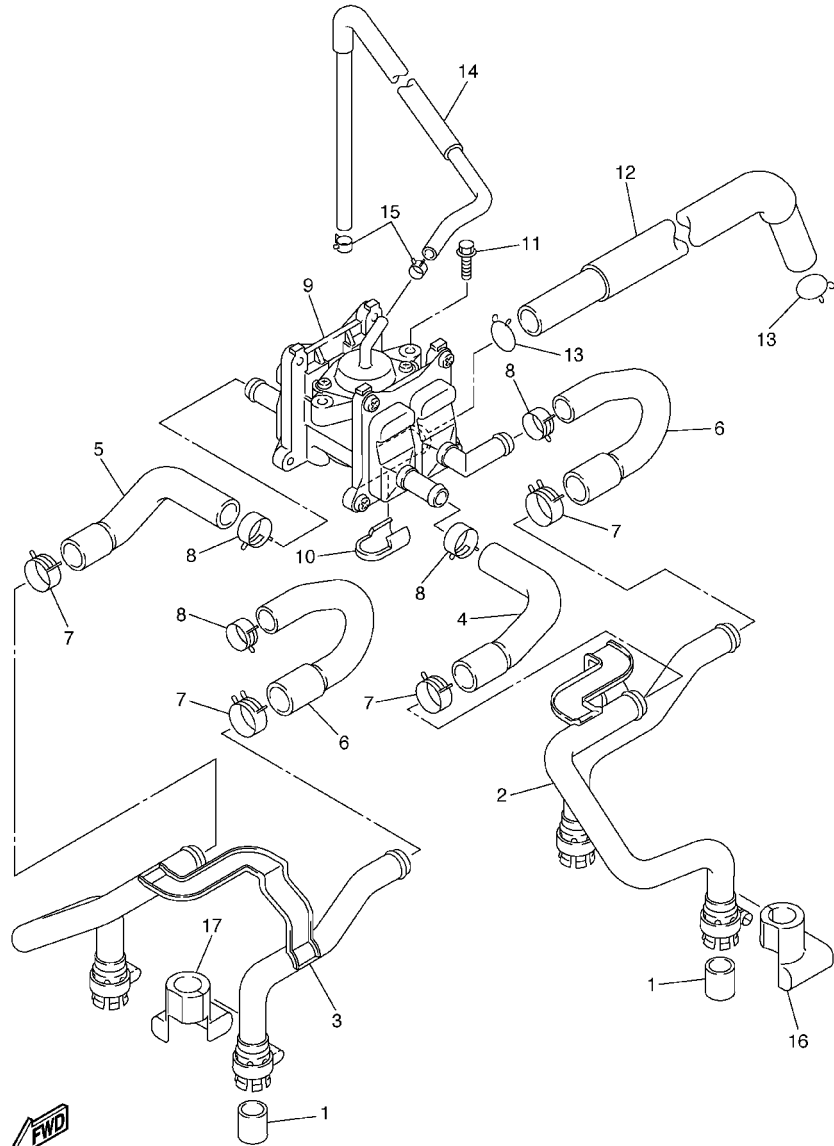

FIG. 9 INTAKE

REF. NO.	PART NO.	DESCRIPTION	5WM1	5WM3	5WM5	5WM6	REMARKS
28	5EA-1442H-00	DAMPER 4	1	1	1	1	
29	95807-06016	BOLT, FLANGE	3	3	3	3	
30	5EA-14294-00	HOSE	1	1	1	1	
31	90467-14193	CLIP	2	2	2	2	
32	5EA-24560-00	FILTER ASSY	1	1	1	1	
33	5EA-14295-00	PIPE, FUEL	1	1	1	1	
34	90467-14193	CLIP	1	1	1	1	
35	90467-13042	CLIP	1	1	1	1	
36	90413-11025	WAY 3	1	1	1	1	
37	5EA-13971-00	PIPE, FUEL 1	1	1	1	1	
38	5EA-13972-00	PIPE, FUEL 2	1	1	1	1	
39	90467-13042	CLIP	2	2	2	2	
40	90467-12052	CLIP	2	2	2	2	
41	5EA-13543-10	HOSE, AIR	1	1	1	1	
42	90467-08075	CLIP	2	2	2	2	
43	5EA-14348-00	PIPE 1	2	2	2	2	

5EAR010-1090

FIG. 10 AIR INDUCTION SYSTEM



5EAT351-2100

REF. NO.	PART NO.	DESCRIPTION	5WM1	5WM3	5WM5	5WM6	REMARKS
1	4KM-14714-01	GASKET, MUFFLER	4	4	4	4	
2	5EA-14872-00	PIPE 2	1	1	1	1	
3	5EA-14873-00	PIPE 3	1	1	1	1	
4	5EA-14881-00	HOSE, BEND 1	1	1	1	1	
5	5EA-14882-00	HOSE, BEND 2	1	1	1	1	
6	5EA-14883-00	HOSE, BEND 3	2	2	2	2	
7	90468-08104	CLIP	4	4	4	4	
8	90467-14150	CLIP	4	4	4	4	
9	5EA-14803-10	AIR INDUCTION SYSTEM ASSY	1	1	1	1	
10	5EA-1479K-00	COVER, 3	1	1	1	1	
11	95027-06014	BOLT, FLANGE	2	2	2	2	
12	5EA-14885-00	HOSE, BEND 5	1	1	1	1	
13	90467-15012	CLIP	2	2	2	2	
14	5EA-13542-00	HOSE, VACUUM SENSING 1	1	1	1	1	
15	90467-08092	CLIP	2	2	2	2	
16	5EA-1479H-01	COVER, 1	2	2	2	2	
17	5EA-1479J-01	COVER 2	2	2	2	2	

FIG. 11 CARBURETOR

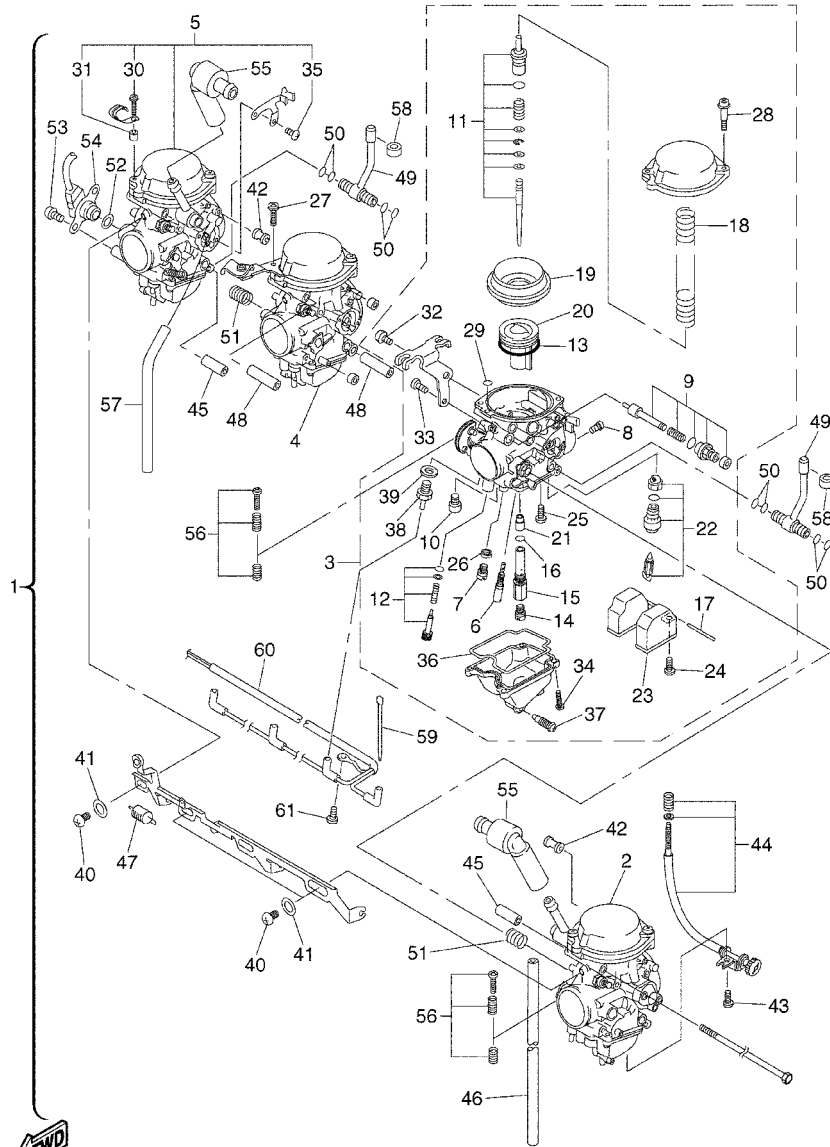

5EAT351-2110

REF. NO.	PART NO.	DESCRIPTION	5WM1	5WM3	5WM5	5WM6	REMARKS
1	5EA-14900-30	CARBURETOR ASSY	1	1	1	1	
2	5EA-14901-30	..CARBURETOR ASSY 1	1	1	1	1	
3	5EA-14902-30	..CARBURETOR ASSY 2	1	1	1	1	
4	5EA-14903-30	..CARBURETOR ASSY 3	1	1	1	1	
5	5EA-14904-30	..CARBURETOR ASSY 4	1	1	1	1	
6	4KM-14142-15	..JET, PILOT (# 15)	1	1	1	1	
7	3G2-1423A-61	..JET, STARTER (#52.5)	1	1	1	1	
8	830-14143-28	..JET, MAIN (#140)	1	1	1	1	
9	5DM-1410A-00	..STARTER SET	1	1	1	1	
10	5EA-14991-00	..SCREW	1	1	1	1	
11	5EA-1490J-10	..NEEDLE SET	1	1	1	1	
12	5EA-14105-00	..PILOT SCREW SET	1	1	1	1	
13	5EL-14561-00	..O-RING	1	1	1	1	
14	3G2-1414A-72	..JET, MAIN (#107.5)	1	1	1	1	
15	5EA-14261-10	..HOLDER	1	1	1	1	
16	583-14561-00	..O-RING	1	1	1	1	
17	127-14186-00	..PIN, FLOAT	1	1	1	1	
18	5EA-14933-00	..SPRING, DIAPHRAGM	1	1	1	1	
19	5EL-24411-00	..DIAPHRAGM	1	1	1	1	
20	5EA-14912-10	..VALVE, THROTTLE	1	1	1	1	
21	5DM-14141-40	..NOZZLE, MAIN	1	1	1	1	
22	5EL-14107-23	..NEEDLE VALVE SET	1	1	1	1	
23	5DM-14985-00	..FLOAT	1	1	1	1	
24	98507-04008	..SCREW, PAN HEAD	1	1	1	1	
25	1FN-14565-00	..SCREW	1	1	1	1	
26	5EL-14918-00	..RING	1	1	1	1	
27	98580-05018	..SCREW, PAN HEAD	1	1	1	1	

FIG. 11 CARBURETOR

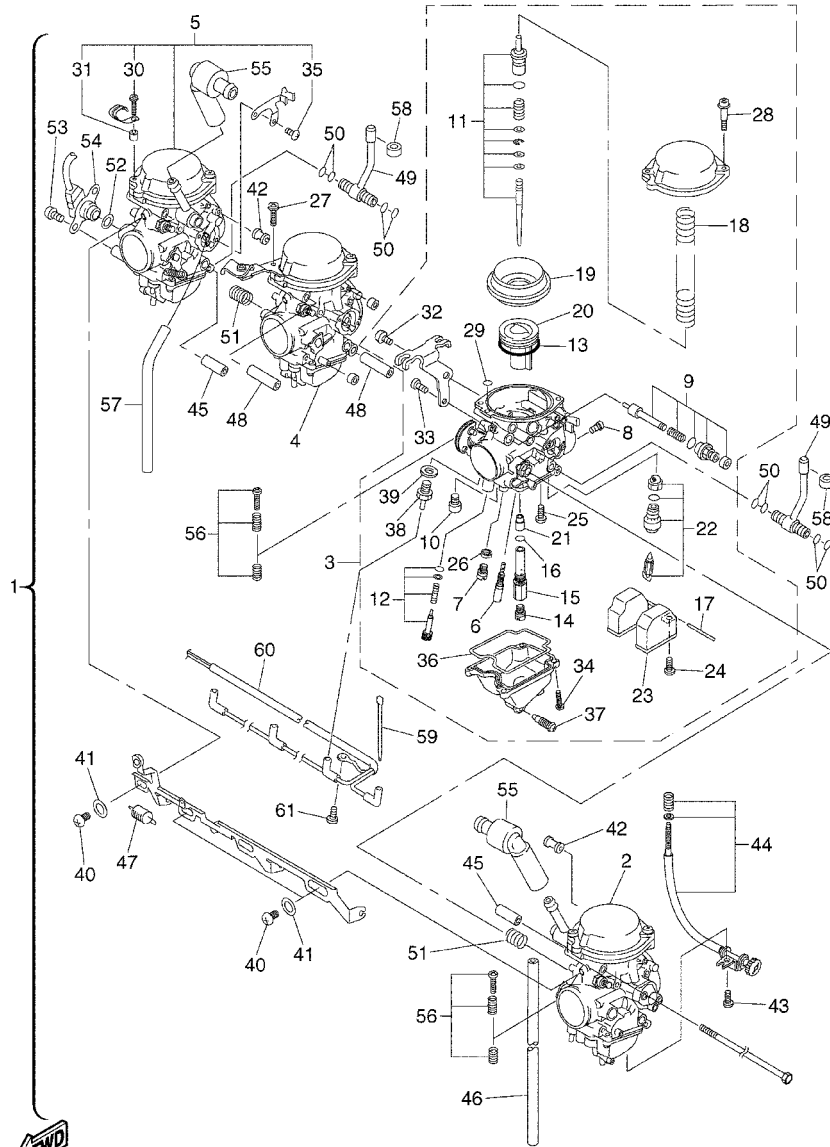

5EAT351-2110

REF. NO.	PART NO.	DESCRIPTION	5WM1	5WM3	5WM5	5WM6	REMARKS
28	4KM-14216-00	..SCREW	2	2	2	2	UR #1,2
	4KM-14216-00	..SCREW	1	1	1	1	UR #3,4
29	354-14147-00	..O-RING	1	1	1	1	
30	98507-05014	..SCREW	1	1	1	1	
31	4KM-14194-00	..RING	1	1	1	1	
32	98707-05010	..SCREW, FLAT HEAD	1	1	1	1	
33	98707-04008	..SCREW, FLAT HEAD	1	1	1	1	
34	98580-04010	..SCREW, PAN HEAD	4	4	4	4	
35	98507-04008	..SCREW, PAN HEAD	2	2	2	2	
36	5DM-14561-00	..O-RING	1	1	1	1	
37	4KP-14191-00	..PLUG, DRAIN	1	1	1	1	
38	5FU-83790-00	..HEATER ASSY	1	1	1	1	UR #2,3
	5FU-83790-10	..HEATER ASSY	1	1	1	1	UR #1,4
39	90201-08016	..WASHER, PLATE	1	1	1	1	
40	5DM-14565-00	..SCREW	3	3	3	3	
41	4NK-14327-00	..PACKING	3	3	3	3	
42	5EA-14167-00	..CONNECTOR	2	2	2	2	
43	97890-05008	..SCREW, PAN HEAD	1	1	1	1	
44	5EA-14103-00	..THROTTLE SCREW SET	1	1	1	1	
45	5EA-14148-00	..PIPE	4	4	4	4	
46	5EA-14987-00	..HOSE	1	1	1	1	
47	4SV-14935-00	..SPRING	1	1	1	1	
48	5EA-14996-00	..PIPE	2	2	2	2	
49	5EA-14389-00	..NIPPLE ASSY	2	2	2	2	
50	36Y-14147-00	..O-RING	8	8	8	8	
51	1HX-14131-00	..SPRING, THROTTLE VALVE	2	2	2	2	
52	4KG-14285-00	..WASHER	1	1	1	1	

FIG. 12 EXHAUST

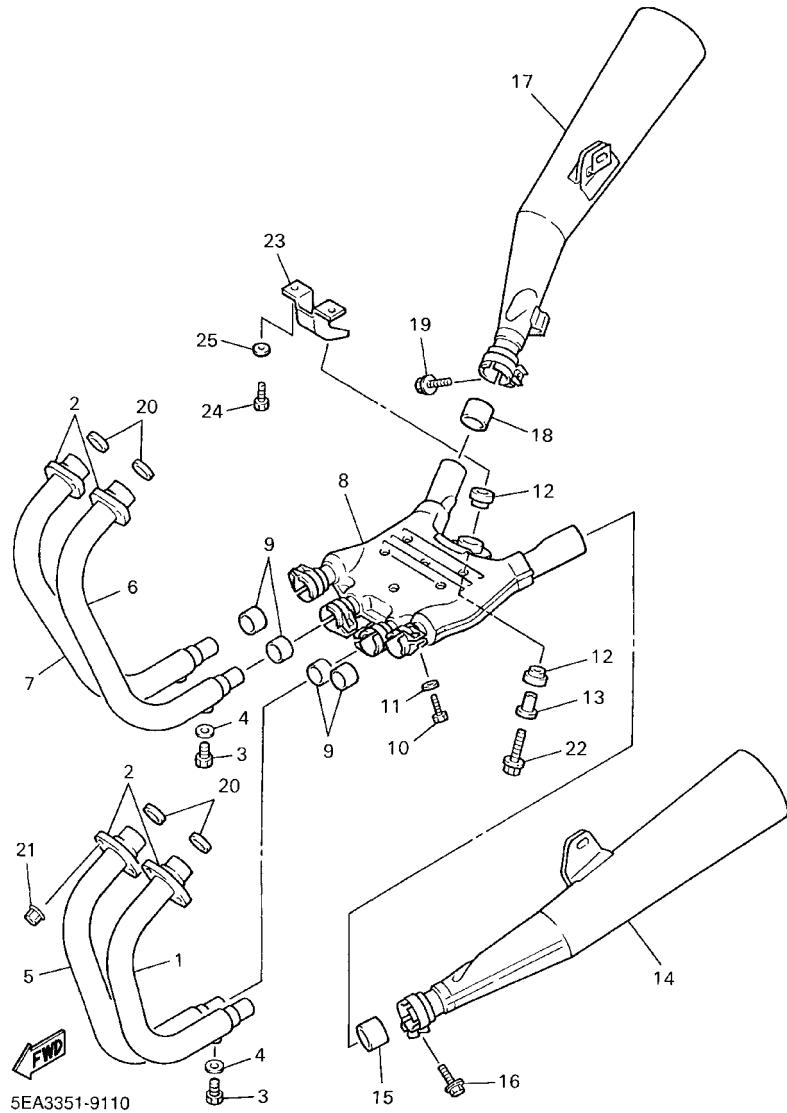

REF. NO.	PART NO.	DESCRIPTION	5WM1	5WM3	5WM5	5WM6	REMARKS
1	4KG-14611-00	PIPE, EXHAUST 1	1	1	1	1	
2	4KG-14612-00	NUT, RING	4	4	4	4	
3	97080-06008	BOLT	4	4	4	4	
4	92990-06600	WASHER, PLATE	4	4	4	4	
5	4KG-14621-00	PIPE, EXHAUST 2	1	1	1	1	
6	4KG-14631-00	PIPE, EXHAUST 3	1	1	1	1	
7	4KG-14641-00	PIPE, EXHAUST 4	1	1	1	1	
8	4PU-14615-00	JOINT, EXHAUST 1	1	1	1	1	
9	3XW-14755-00	GASKET, SILENCER	4	4	4	4	
10	97024-08025	BOLT	4	4	4	4	
11	92904-08600	WASHER	4	4	4	4	
12	36Y-14747-00	DAMPER, MUFFLER	2	2	2	2	
13	4G0-14638-00	COLLAR	1	1	1	1	
14	5EA-14711-20	MUFFLER 1	1	1	1	1	
15	3XW-14714-00	GASKET, MUFFLER	1	1	1	1	
16	95814-08025	BOLT, FLANGE	1	1	1	1	
17	5EA-14721-20	MUFFLER 2	1	1	1	1	
18	3XW-14714-00	GASKET, MUFFLER	1	1	1	1	
19	95814-08025	BOLT, FLANGE	1	1	1	1	
20	4BE-14613-00	GASKET, EXHAUST PIPE	4	4	4	4	
21	95604-08200	NUT, U FLANGE	8	8	8	8	
22	95807-10040	BOLT, FLANGE	1	1	1	1	
23	4KG-14791-00	STAY, MUFFLER	1	1	1	1	
24	97017-08025	BOLT	2	2	2	2	
25	92907-08600	WASHER, PLATE	2	2	2	2	

FIG. 13 CRANKCASE

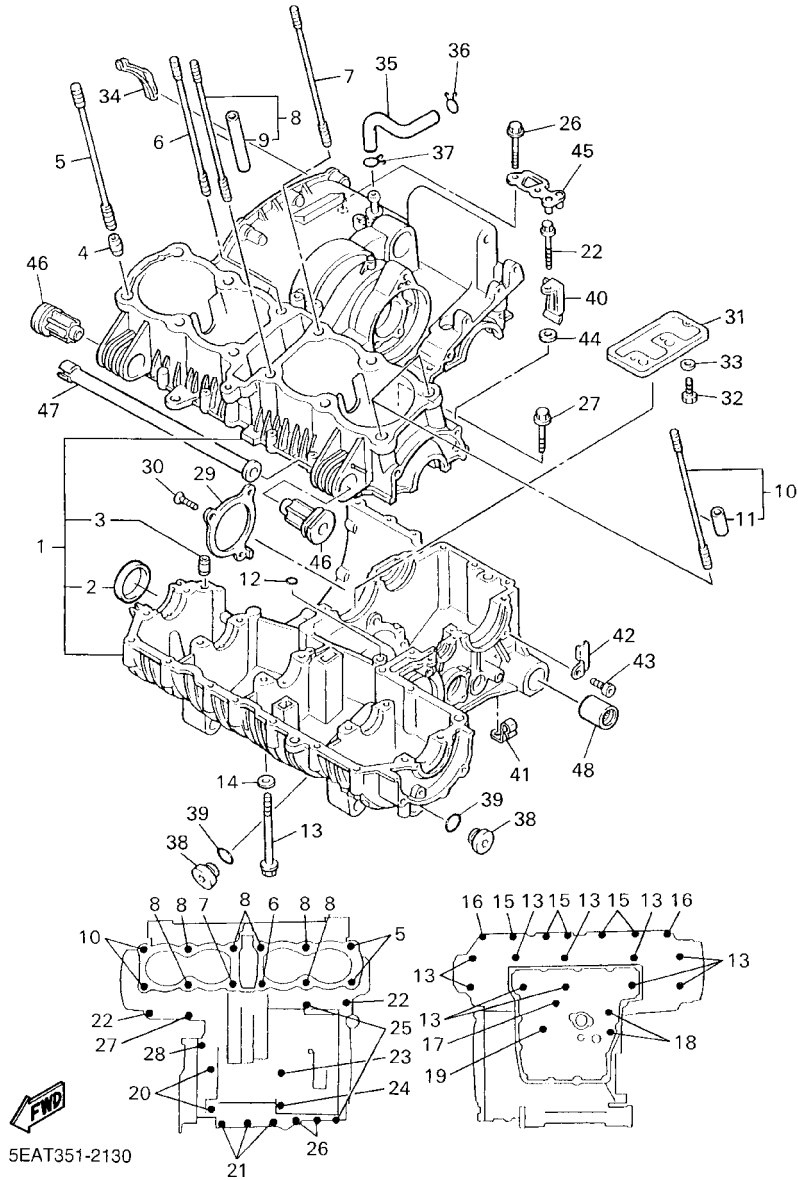

5EAT351-2130

REF. NO.	PART NO.	DESCRIPTION	5WM1	5WM3	5WM5	5WM6	REMARKS
1	5EA-15100-00	CRANKCASE ASSY	1		1		
	5EA-15100-10	CRANKCASE ASSY		1		1	
2	4H7-15167-10	.PLUG, BLIND 1	1	1	1	1	
3	99530-12016	.PIN, DOWEL	2	2	2	2	
4	99530-14016	PIN, DOWEL	2	2	2	2	
5	90116-10563	BOLT, STUD	2	2	2	2	
6	90116-10561	BOLT, STUD	1	1	1	1	
7	90116-10562	BOLT, STUD	1	1	1	1	
8	3XW-11363-01	BOLT, CYLINDER HOLDING 3	6	6	6	6	
9	3XW-1111J-00	.PIPE 1	1	1	1	1	
10	3XW-11364-01	BOLT, CYLINDER HOLDING 4	2	2	2	2	
11	3XW-1112J-00	.PIPE 2	1	1	1	1	
12	93210-07135	O-RING	1	1	1	1	
13	95814-08100	BOLT, FLANGE	10		10		
	90105-080A3	BOLT, FLANGE		10		10	
14	90201-08366	WASHER, PLATE	7	7	7	7	
15	95814-08045	BOLT, FLANGE	5		5		
	95817-08045	BOLT, FLANGE		5		5	
16	95814-10050	BOLT, FLANGE	2		2		
	90105-100A4	BOLT, FLANGE		2		2	
17	95817-06110	BOLT, FLANGE	1	1	1	1	
18	95817-06095	BOLT, FLANGE	2	2	2	2	
19	95817-06040	BOLT, FLANGE	1	1	1	1	
20	95814-08055	BOLT, FLANGE	2		2		
	95817-08055	BOLT, FLANGE		2		2	
21	95814-10060	BOLT, FLANGE	3		3		
	95817-10060	BOLT, FLANGE		3		3	

FIG. 13 CRANKCASE

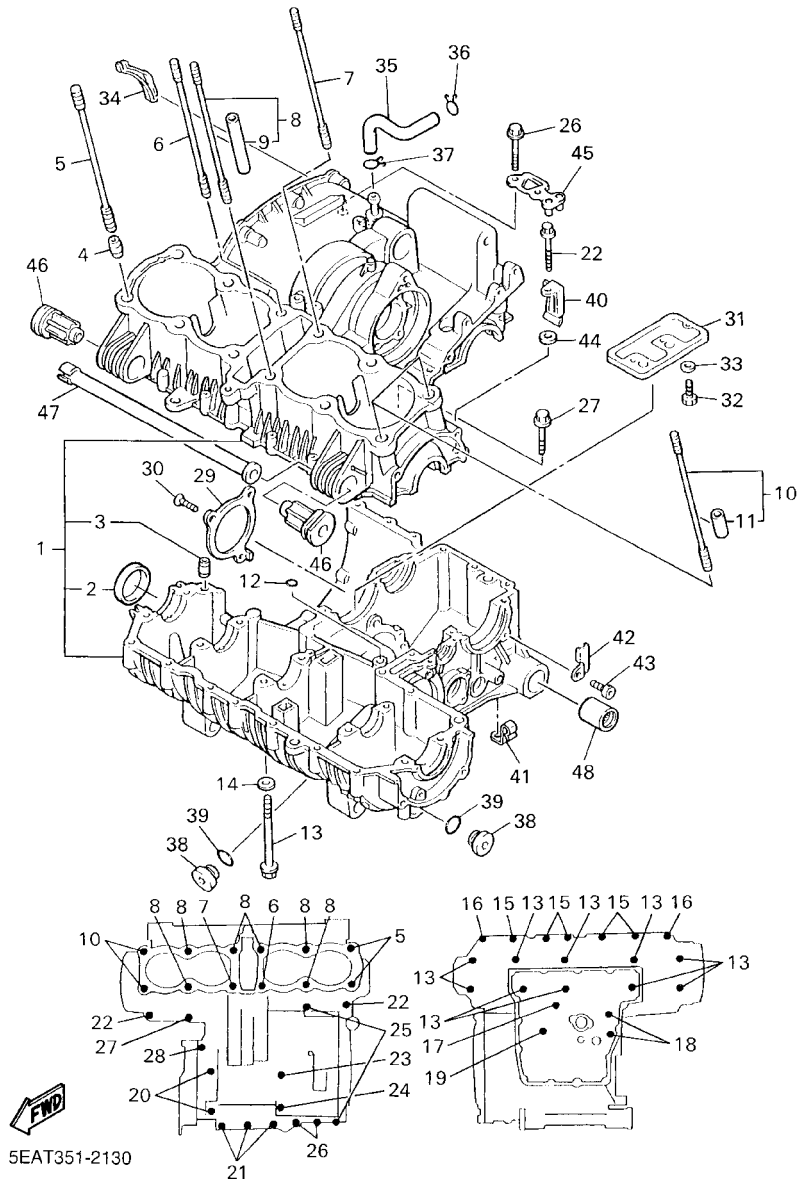

5EAT351-2130

REF. NO.	PART NO.	DESCRIPTION	5WM1	5WM3	5WM5	5WM6	REMARKS
22	95814-06050	BOLT, FLANGE	2		2		
	90105-060A2	BOLT, FLANGE		2		2	
23	90105-065A9	BOLT, WASHER BASED	1		1		
	95817-06125	BOLT, FLANGE		1		1	
24	95814-06070	BOLT, FLANGE	1		1		
	95817-06070	BOLT, FLANGE		1		1	
25	95814-06065	BOLT, FLANGE	2		2		
	90105-060A1	BOLT, FLANGE		2		2	
26	95814-06055	BOLT, FLANGE	2		2		
	95817-06055	BOLT, FLANGE		2		2	
27	95814-06040	BOLT, FLANGE	1		1		
	95817-06040	BOLT, FLANGE		1		1	
28	95814-06030	BOLT, FLANGE	1		1		
	95817-06030	BOLT, FLANGE		1		1	
29	36Y-15383-01	PLATE, BEARING COVER	1	1	1	1	
30	90151-06025	SCREW, COUNTERSUNK	3	3	3	3	
31	36Y-15412-00	PLATE, OIL GUIDE	1	1	1	1	
32	97007-05010	BOLT	3	3	3	3	
33	92907-05600	WASHER, PLATE	3	3	3	3	
34	1TX-15365-00	GROMMET	1	1	1	1	
35	4KG-11166-00	PIPE, BREATHER 1	1	1	1	1	
36	90467-14015	CLIP	1	1	1	1	
37	90467-14015	CLIP	1	1	1	1	
38	4H7-15189-00	PLUG	3		3		
	4K0-15189-00	PLUG		3		3	
39	93210-207A0	O-RING	3	3	3	3	
40	90465-10027	CLAMP	1	1	1	1	

FIG. 14 CRANKCASE COVER 1

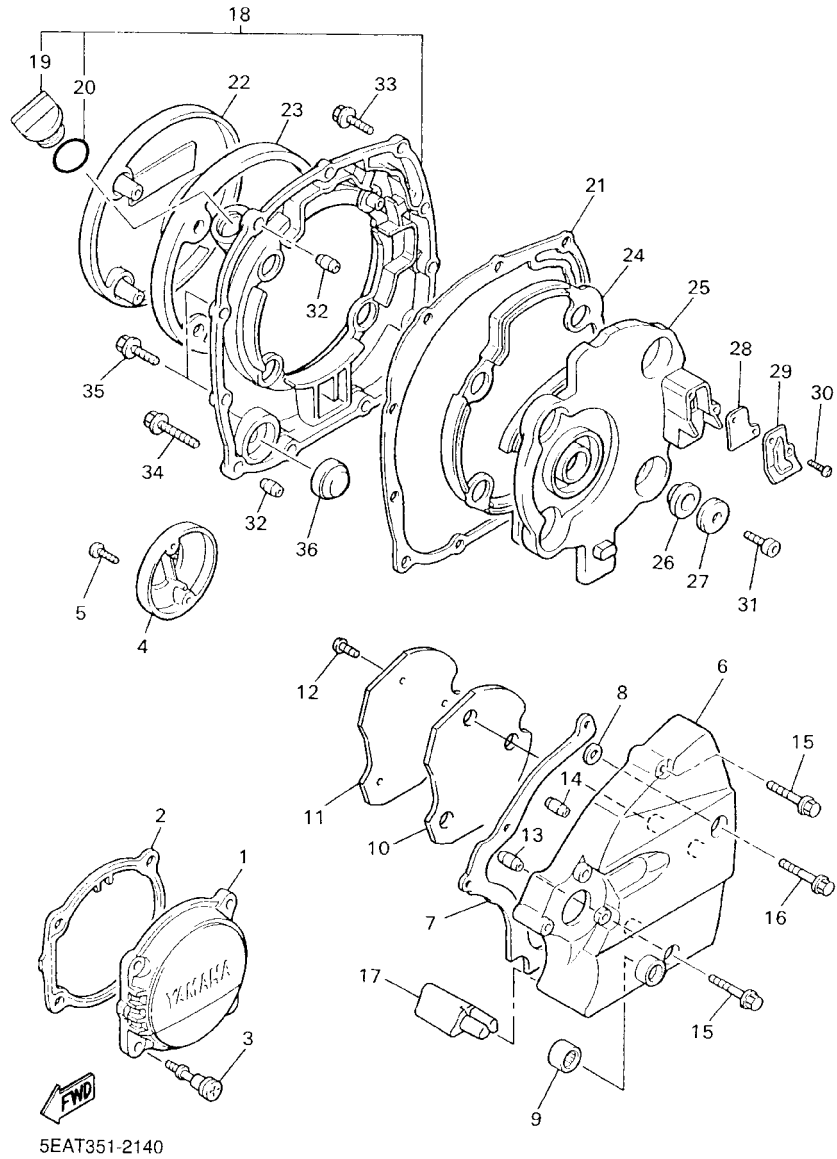

REF. NO.	PART NO.	DESCRIPTION	5WM1	5WM3	5WM5	5WM6	REMARKS
1	5EA-15416-10	COVER, OIL PUMP	1		1		
	5EA-15416-20	COVER, OIL PUMP		1		1	
2	4KG-15449-00	RING, RUBBER	1	1	1	1	
3	5EA-15481-00	BOLT 1	4		4		
	4KG-15481-01	BOLT 1		4		4	
4	5EA-15426-10	COVER, OIL PUMP 2	1		1		
	5EA-15426-20	COVER, OIL PUMP 2		1		1	
5	90154-05079	SCREW, BINDING	2		2		
	90154-05073	SCREW, BINDING		2		2	
6	5EA-15411-10	COVER, CRANKCASE 1	1		1		
	5EA-15411-20	COVER, CRANKCASE 1		1		1	
7	5EA-15451-00	GASKET, CRANKCASE COVER 1	1	1	1	1	
8	4CR-15467-00	GASKET	1	1	1	1	
9	93317-21288	BEARING	1	1	1	1	
10	5EA-15316-00	DAMPER, ENGINE MOUNT 1	1	1	1	1	
11	5EA-15427-00	COVER, CAP 2	1	1	1	1	
12	90110-06004	BOLT, HEXAGON SOCKET HEAD	3	3	3	3	
13	99530-10116	PIN, DOWEL	1	1	1	1	
14	99530-08016	PIN, DOWEL	1	1	1	1	
15	95024-06040	BOLT, FLANGE	2		2		
	90105-06792	BOLT, FLANGE		2		2	
16	95024-06050	BOLT, FLANGE	1		1		
	90105-06798	BOLT, FLANGE		1		1	
17	5EA-15326-00	DAMPER, ENGINE MOUNT 2	1	1	1	1	
18	5EA-W1543-00	CRANKCASE COVER ASSY 2	1		1		
	3XW-W1543-02	CRANKCASE COVER ASSY 2		1		1	
19	2H7-15363-00	.PLUG, OIL	1	1	1	1	

FIG. 14 CRANKCASE COVER 1

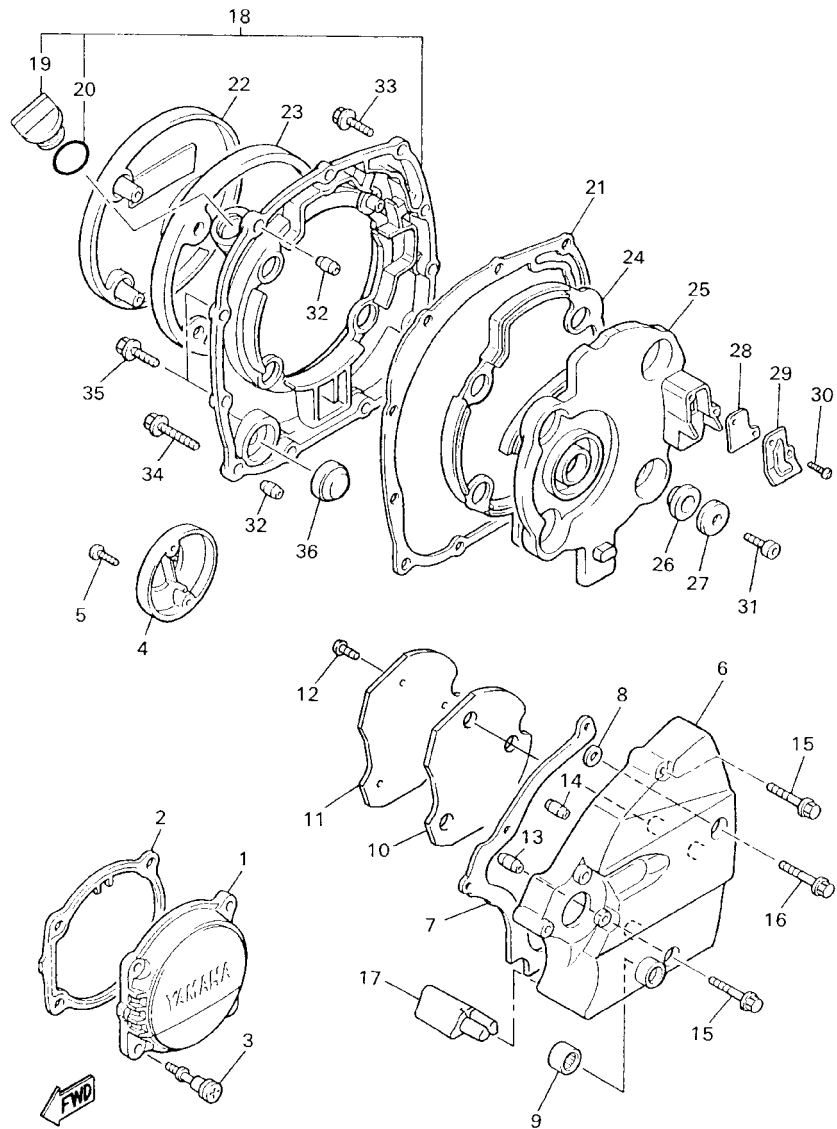

5EAT351-2140

REF. NO.	PART NO.	DESCRIPTION	5WM1	5WM3	5WM5	5WM6	REMARKS
20	93210-27370	.O-RING	1	1	1	1	
21	4CR-15461-01	GASKET, CRANKCASE COVER 2	1	1	1	1	
22	36Y-15417-10	COVER, CAP	1	1	1	1	
23	36Y-15449-00	RING, RUBBER	1	1	1	1	
24	1TX-15367-00	GROMMET	1	1	1	1	
25	1TX-15346-00	BREATHER 1	1	1	1	1	
26	4H7-15486-00	GROMMET	4	4	4	4	
27	90209-06096	WASHER	4	4	4	4	
28	4CR-15374-00	GASKET, BREATHER	1	1	1	1	
29	1TX-15333-00	COVER	1	1	1	1	
30	90157-05095	SCREW, PAN HEAD	2	2	2	2	
31	97007-06012	BOLT	4	4	4	4	
32	99530-10114	PIN, DOWEL	2	2	2	2	
33	95024-06020	BOLT, FLANGE	7		7		
	90105-06790	BOLT, FLANGE		7		7	
34	95024-06035	BOLT, FLANGE	2		2		
	90105-06799	BOLT, FLANGE		2		2	
35	95024-06025	BOLT, FLANGE	2		2		
	90105-060A0	BOLT, FLANGE		2		2	
36	2H7-15361-00	GAUGE, LEVEL	1	1	1	1	

FIG. 15 STARTER

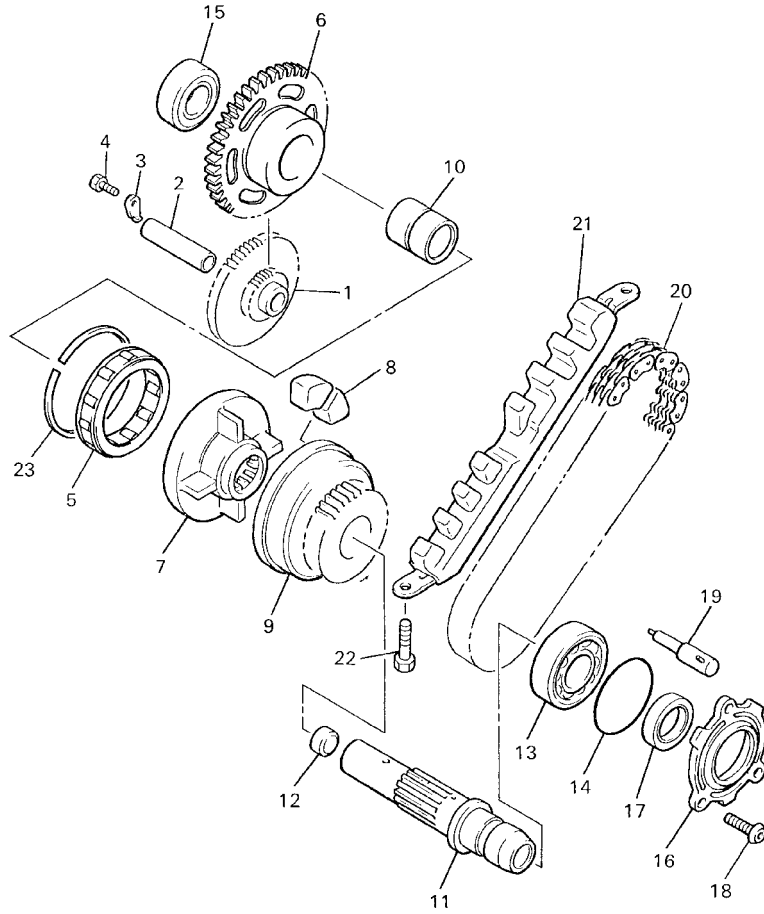

REF. NO.	PART NO.	DESCRIPTION	5WM1	5WM3	5WM5	5WM6	REMARKS
1	36Y-15512-01	GEAR, IDLER 1 (12/55T)	1	1	1	1	
2	36Y-15521-01	SHAFT 1	1	1	1	1	
3	2H7-15531-00	PLATE, STOPPER	1	1	1	1	
4	97027-06012	BOLT	1	1	1	1	
5	4KM-15580-00	STARTER CLUTCH OUTER ASSY	1	1	1	1	
6	4KG-15517-00	GEAR, IDLER 2 (45T)	1	1	1	1	
7	4KG-15524-00	WHEEL, STARTER	1	1	1	1	
8	4H7-16155-01	ABSORBER 1	4	4	4	4	
9	36Y-15519-00	SPROCKET, STARTER 2	1	1	1	1	
10	90387-201L2	COLLAR	1	1	1	1	
11	3CV-15522-00	SHAFT 2	1	1	1	1	
12	90331-15039	PLUG	1	1	1	1	
13	93306-20545	BEARING	1	1	1	1	
14	93210-47440	O-RING	1	1	1	1	
15	93306-00401	BEARING (B6004)	1	1	1	1	
16	36Y-15163-00	HOUSING, BEARING 1	1	1	1	1	
17	93102-25253	OIL SEAL	1	1	1	1	
18	90149-06228	SCREW	3	3	3	3	
19	36Y-13454-00	NOZZLE	1	1	1	1	
20	4FM-11456-00	CHAIN, PRIMARY	1	1	1	1	
21	36Y-11474-00	GUIDE, UPPER	1	1	1	1	
22	97027-06016	BOLT	2	2	2	2	
23	99009-62500	CIRCLIP	1	1	1	1	



4PU351-7140

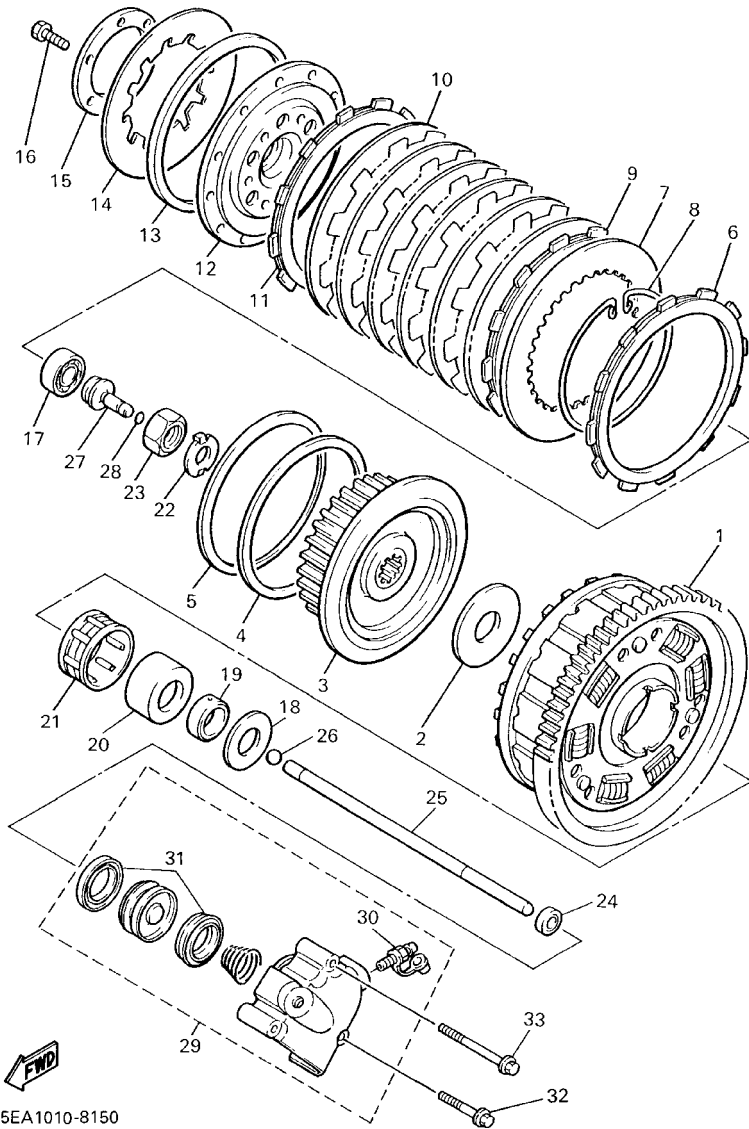

5EA1010-8150

FIG. 16 CLUTCH

REF. NO.	PART NO.	DESCRIPTION	5WM1	5WM3	5WM5	5WM6	REMARKS
1	1TX-16150-01	PRIMARY DRIVEN GEAR COMP.	1	1	1	1	
2	36Y-16154-00	PLATE, THRUST 1	1	1	1	1	
3	36Y-16371-00	BOSS, CLUTCH	1	1	1	1	
4	36Y-16384-00	PLATE, SEAT	1	1	1	1	
5	36Y-16383-00	SPRING, CLUTCH BOSS	1	1	1	1	
6	36Y-16331-00	PLATE, FRICTION 2	1	1	1	1	
7	2H7-16325-00	PLATE, CLUTCH 2	1	1	1	1	
8	2H7-16385-00	RING, CLUTCH BOSS	1	1	1	1	
9	341-16321-13	PLATE, FRICTION	6	6	6	6	
10	2H7-16325-00	PLATE, CLUTCH 2	6	6	6	6	
11	36Y-16331-00	PLATE, FRICTION 2	1	1	1	1	
12	36Y-16351-00	PLATE, PRESSURE 1	1	1	1	1	
13	36Y-16335-00	HOUSING, SPRING	1	1	1	1	
14	5JW-16334-00	SPRING, CLUTCH 2	1	1	1	1	
15	1TX-16352-00	PLATE, PRESSURE 2	1	1	1	1	
16	97027-06016	BOLT	6	6	6	6	
17	93306-00304	BEARING (B6003C4)	1	1	1	1	
18	90201-286H8	WASHER, PLATE	1	1	1	1	
19	90387-284K1	COLLAR	1	1	1	1	
20	36Y-16181-00	SPACER 1	1	1	1	1	
21	93310-350M3	BEARING	1	1	1	1	
22	90215-25218	WASHER, LOCK	1	1	1	1	
23	90170-20323	NUT	1	1	1	1	
24	93109-08061	O-RING	1	1	1	1	
25	4KG-16357-00	ROD, PUSH 2	1	1	1	1	
26	93511-32017	BALL	1	1	1	1	
27	4KG-16356-00	ROD, PUSH 1	1	1	1	1	

FIG. 17 TRANSMISSION

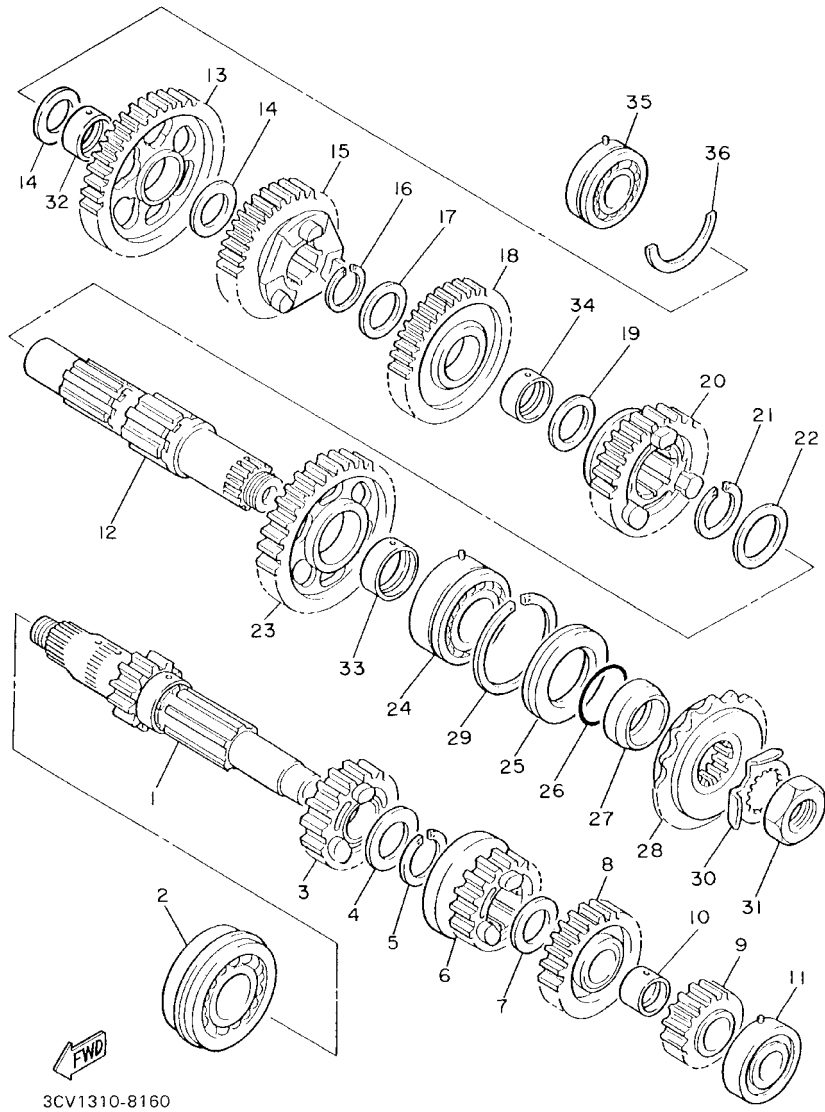

REF. NO.	PART NO.	DESCRIPTION	5WM1	5WM3	5WM5	5WM6	REMARKS
1	4KG-W1741-00	MAIN AXLE ASSY (14T)	1	1	1	1	
2	93306-00008	BEARING	1	1	1	1	
3	4CC-17141-00	GEAR, 4TH PINION (24T)	1	1	1	1	
4	90209-25196	WASHER	1	1	1	1	
5	93440-28062	CIRCLIP	1	1	1	1	
6	1TX-17131-00	GEAR, 3RD PINION (21T)	1	1	1	1	
7	90201-226H9	WASHER, PLATE	1	1	1	1	
8	1TX-17151-00	GEAR, 5TH PINION (26T)	1	1	1	1	
9	3CV-17121-00	GEAR, 2ND PINION (18T)	1	1	1	1	
10	90387-220R2	COLLAR	1	1	1	1	
11	93306-30434	BEARING	1	1	1	1	
12	5EA-17421-00	AXLE, DRIVE	1	1	1	1	
13	1TX-17211-00	GEAR, 1ST WHEEL (40T)	1	1	1	1	
14	90201-257H0	WASHER, PLATE	2	2	2	2	
15	5EA-17241-00	GEAR, 4TH WHEEL (31T)	1	1	1	1	
16	93440-30077	CIRCLIP	1	1	1	1	
17	90209-27192	WASHER	1	1	1	1	
18	1TX-17231-00	GEAR, 3RD WHEEL (33T)	1	1	1	1	
19	90201-307H1	WASHER, PLATE	1	1	1	1	
20	1TX-17251-00	GEAR, 5TH WHEEL (29T)	1	1	1	1	
21	93440-34025	CIRCLIP	1	1	1	1	
22	90209-32231	WASHER	1	1	1	1	
23	3CV-17221-00	GEAR, 2ND WHEEL (36T)	1	1	1	1	
24	93305-20605	BEARING	1	1	1	1	
25	93102-40330	OIL SEAL	1	1	1	1	
26	93210-30660	O-RING	1	1	1	1	
27	90387-3003P	COLLAR	1	1	1	1	

FIG. 18 SHIFT CAM. FORK

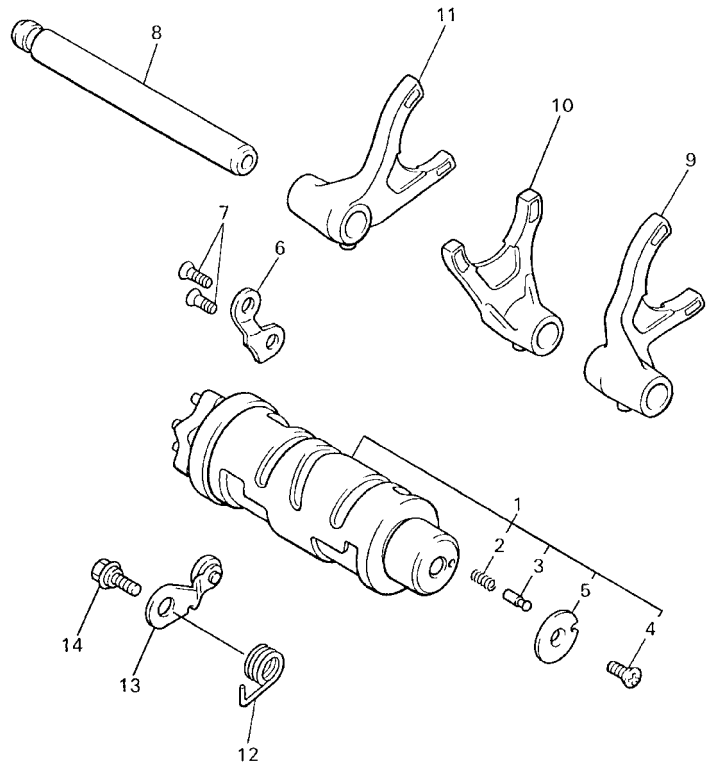

REF. NO.	PART NO.	DESCRIPTION	5WM1	5WM3	5WM5	5WM6	REMARKS
1	5EA-18540-01	SHIFT CAM ASSY	1	1	1	1	
2	90501-06022	.SPRING, COMPRESSION	1	1	1	1	
3	4UN-18542-00	.POINT, NEUTRAL	1	1	1	1	
4	90149-05321	.SCREW	1	1	1	1	
5	4UN-18566-00	.PLATE, SIDE 2	1	1	1	1	
6	36Y-18562-00	PLATE, STOPPER 2	1	1	1	1	
7	98707-06016	SCREW, FLAT HEAD	2	2	2	2	
8	4BR-18531-00	BAR, SHIFT FORK GUIDE 1	1	1	1	1	
9	3XW-18511-00	FORK, SHIFT 1	1	1	1	1	
10	4KG-18512-00	FORK, SHIFT 2	1	1	1	1	
11	3XW-18513-00	FORK, SHIFT 3	1	1	1	1	
12	90508-233B5	SPRING, TORSION	1	1	1	1	
13	5RT-18140-00	STOPPER LEVER ASSY	1	1	1	1	
14	90109-063F7	BOLT	1	1	1	1	



5EA1010-8170

FIG. 19 SHIFT SHAFT

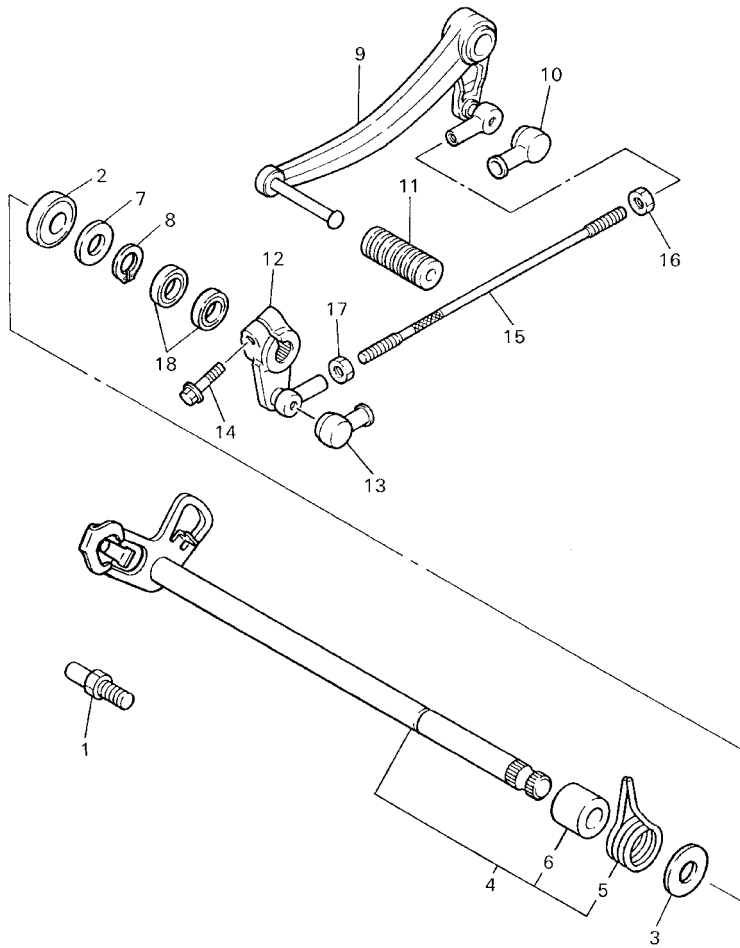

4KG010-4180

REF. NO.	PART NO.	DESCRIPTION	5WM1	5WM3	5WM5	5WM6	REMARKS
1	4G0-18127-00	STOPPER, SCREW	1	1	1	1	
2	93102-12106	OIL SEAL (SD 12-22-5 HS)	1	1	1	1	
3	90201-12588	WASHER, PLATE	1	1	1	1	
4	4KG-18101-01	SHIFT SHAFT ASSY	1	1	1	1	
5	90508-32682	.SPRING, TORSION	1	1	1	1	
6	90387-114K8	.COLLAR	1	1	1	1	
7	90201-12575	WASHER, PLATE	1	1	1	1	
8	99001-10600	CIRCLIP	1	1	1	1	
9	4KG-18111-00	PEDAL, SHIFT	1	1	1	1	
10	2H9-18154-00	COVER, DUST	1	1	1	1	
11	5EB-18113-00	COVER, SHIFT PEDAL	1	1	1	1	
12	2GH-18112-01	ARM, SHIFT	1	1	1	1	
13	2H9-18154-00	COVER, DUST	1	1	1	1	
14	95824-06020	BOLT, FLANGE	1	1	1	1	
15	2GV-18115-00	ROD, SHIFT	1	1	1	1	
16	90170-06228	NUT(COUNTER CLOCKWISE)	1	1	1	1	
17	95304-06700	NUT	1	1	1	1	
18	93109-12075	OIL SEAL	2	2	2	2	

FIG. 20 FRAME

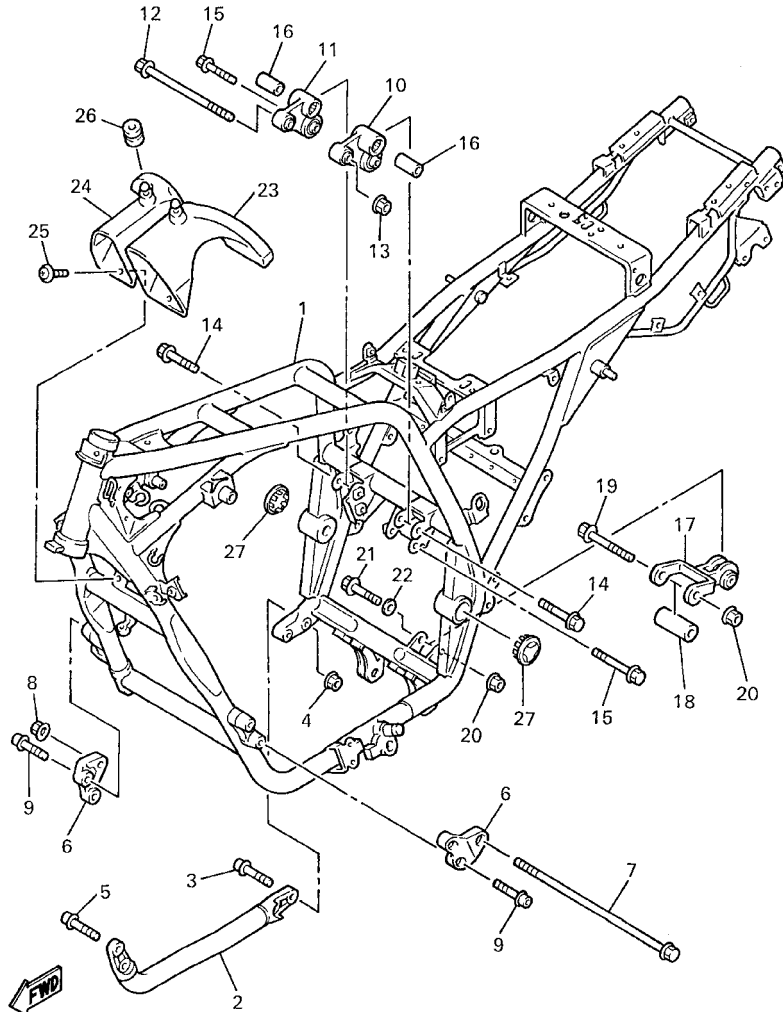

5EA1010-8190

REF. NO.	PART NO.	DESCRIPTION	5WM1	5WM3	5WM5	5WM6	REMARKS
1	5EA-21110-21-33	FRAME COMP.	1	1			YB
	5EA-21110-30-33	FRAME COMP.			1	1	YB
2	4KG-21150-00-33	DOWN TUBE COMP.2	1	1	1	1	YB
3	90110-08232	BOLT, HEXAGON SOCKET HEAD	2	2	2	2	
4	95607-08200	NUT, SELF-LOCKING	2	2	2	2	
5	90110-08231	BOLT, HEXAGON SOCKET HEAD	2	2	2	2	
6	4KG-21315-02	STAY, ENGINE 2	2	2	2	2	
7	90105-10313	BOLT, FLANGE	1	1	1	1	
8	90179-10658	NUT	1	1	1	1	
9	90110-08199	BOLT, HEXAGON SOCKET HEAD	4	4	4	4	
10	4KG-2140X-00	ENGINE BRACKET SUB-COMP. 1	1	1	1	1	
11	4KG-2140Y-00	ENGINE BRACKET SUB-COMP. 2	1	1	1	1	
12	90105-10300	BOLT, FLANGE	1	1	1	1	
13	90179-10658	NUT	1	1	1	1	
14	90105-10402	BOLT, FLANGE	2	2	2	2	
15	90105-12425	BOLT, FLANGE	2	2	2	2	
16	90387-1003V	COLLAR	2	2	2	2	
17	4KG-21400-00	ENGINE BRACKET COMP.	1	1	1	1	
18	90387-1003W	COLLAR	1	1	1	1	
19	90105-10609	BOLT, FLANGE	1	1	1	1	
20	90179-10247	NUT	2	2	2	2	
21	90105-10323	BOLT, FLANGE	1	1	1	1	
22	92907-10200	WASHER, PLAIN	1	1	1	1	
23	5EA-2838N-00	DUCT 1	1	1	1	1	
24	5EA-2838R-00	DUCT 2	1	1	1	1	
25	90159-06058	SCREW, WITH WASHER	2	2	2	2	
26	90480-13567	GROMMET	2	2	2	2	

FIG. 21 FENDER

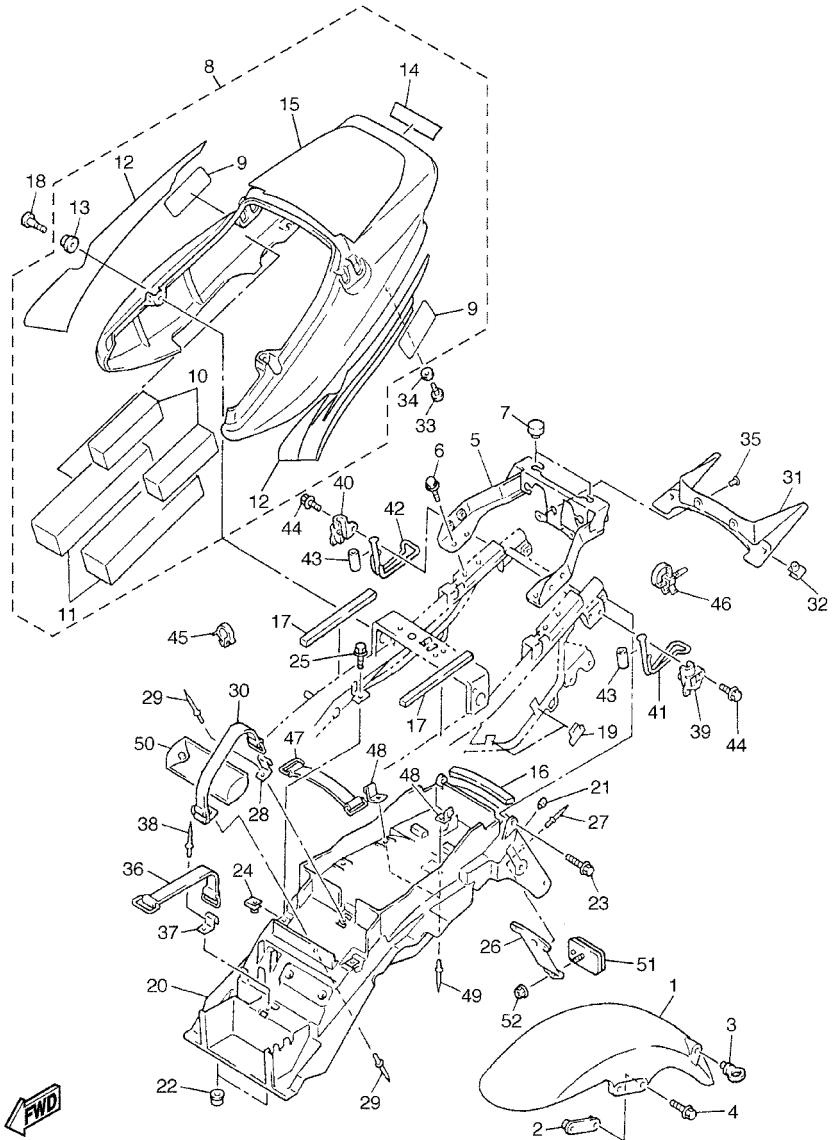

5WM1300-B210

REF. NO.	PART NO.	DESCRIPTION	5WM1	5WM3	5WM5	5WM6	REMARKS
1	4KG-21511-01-4B	FENDER, FRONT	1	1	1	1	BL2
2	4KG-21512-00	BRACKET, FENDER	2	2	2	2	
3	1A8-21518-00	HOLDER, CABLE	1	1	1	1	
4	95024-06025	BOLT, FLANGE	4	4	4	4	
5	5EA-2117E-00	BRACKET, TAILLIGHT	1	1	1	1	
6	95817-08012	BOLT, FLANGE	4	4	4	4	
7	22W-24741-00	PAD, SEAT	2	2	2	2	
8	5EA-Y2165-N0-4B	COVER, REAR FENDER	1		1		UR BL2 FOR BL2
	5EA-Y2165-R0-4B	COVER, REAR FENDER	1		1		UR BL2 FOR DPBMC
	5EA-Y2165-P0-4B	COVER, REAR FENDER			1	1	BL2 FOR RYC1
9	4HD-2218A-00	.EMBLEM, REAR ARM	2	2	2	2	
10	4KG-21778-00	.DAMPER, LOCATING 1	2	2	2	2	
11	5EA-21779-10	.DAMPER, LOCATING 2	2	2	2	2	
12	5WM-21660-00	.GRAPHIC, COVER RR, FENDER SET	1		1		UR FOR BL2
	5WM-21660-10	.GRAPHIC, COVER RR, FENDER SET	1		1		UR FOR DPBMC
	5WM-21660-10	.GRAPHIC, COVER RR, FENDER SET			1	1	FOR RYC1
13	90480-13398	.GROMMET	2	2	2	2	
14	99247-00080	.EMBLEM, YAMAHA	1	1	1	1	
15	5WM-2165C-00	.GRAPHIC 1	1		1		FOR DPBMC
	5WM-2165C-10	.GRAPHIC 1			1	1	FOR RYC1
16	3YF-2414J-10	DAMPER, PLATE 2	1	1	1	1	
17	4HM-2139X-00	DAMPER	2	2	2	2	
18	90150-06036	SCREW, ROUND HEAD	2	2	2	2	
19	2N4-21717-00	DAMPER	3	3	3	3	
20	5EA-21611-00	FENDER, REAR	1	1	1	1	
21	4G0-21639-00	DAMPER 2	1	1	1	1	
22	90480-13369	GROMMET	2	2	2	2	

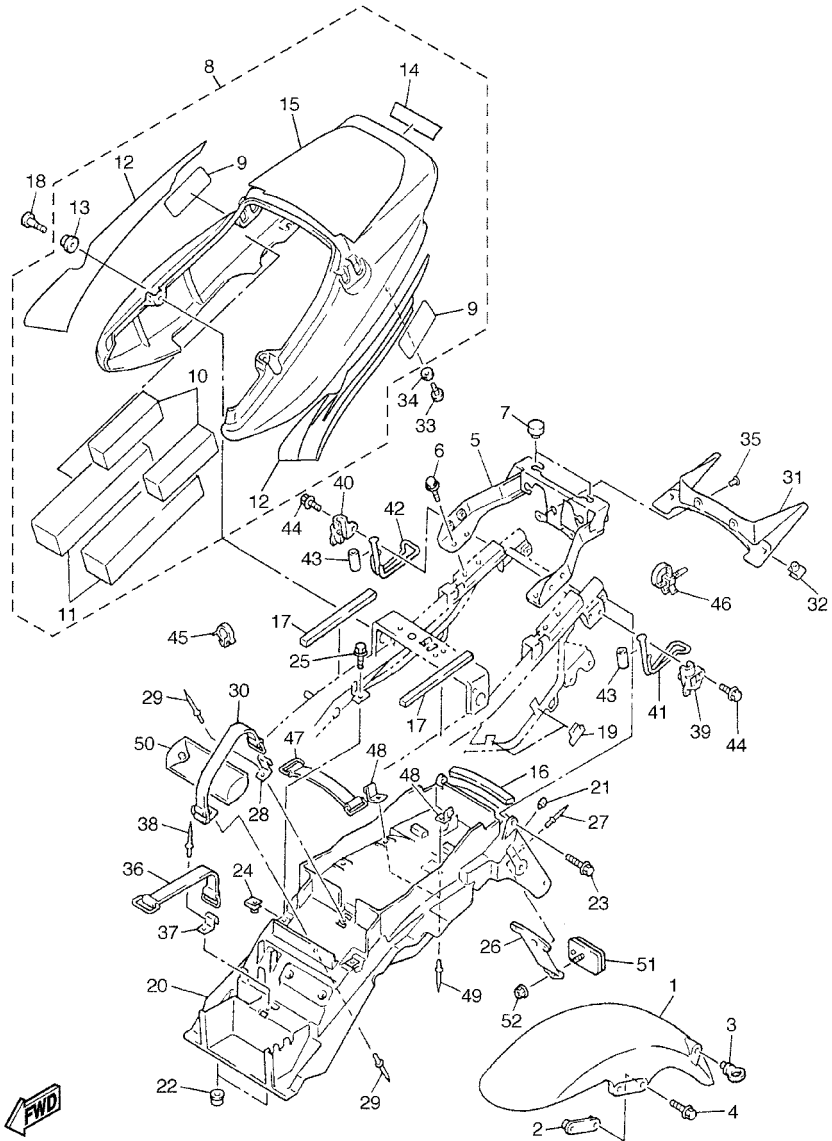

5WM1300-B210

FIG. 21 FENDER

REF. NO.	PART NO.	DESCRIPTION	5WM1	5WM3	5WM5	5WM6	REMARKS
23	90109-063F1	BOLT	2	2	2	2	
24	90183-06053	NUT, SPRING	2	2	2	2	
25	95807-06016	BOLT, FLANGE	2	2	2	2	
26	5EA-85132-00	BRACKET, REFLECTOR 1	1	1			
	4KG-85132-00	BRACKET, REFLECTOR 1			1	1	
27	90267-40076	RIVET, BLIND	2	2	2	2	
28	4HM-2162A-00	HOOK	1	1	1	1	
29	90267-40076	RIVET, BLIND	2	2	2	2	
30	4HM-82131-00	BAND, BATTERY	1	1	1	1	
31	5EA-2163F-00	COVER, REAR FENDER 3	1	1	1	1	
32	90183-05061	NUT, SPRING	2	2	2	2	
33	90154-05059	SCREW, BINDING	2	2	2	2	
34	90202-06113	WASHER, PLATE	2	2	2	2	
35	90269-06081	RIVET	2	2	2	2	
36	4WM-82131-00	BAND, BATTERY	1	1	1	1	
37	4HM-2162A-00	HOOK	1	1	1	1	
38	90267-40076	RIVET, BLIND	1	1	1	1	
39	4KG-21331-00	HOOK, SIDE COVER 1	1	1	1	1	
40	4KG-21332-00	HOOK, SIDE COVER 2	1	1	1	1	
41	5EA-21654-00	WIRE	1	1	1	1	
42	5EA-21664-00	WIRE, 2	1	1	1	1	
43	4KG-21639-00	DAMPER 2	2	2	2	2	
44	95807-06016	BOLT, FLANGE	2	2	2	2	
45	90464-15157	CLAMP	1	1	1	1	
46	90464-12036	CLAMP	1	1	1	1	
47	120-82131-00	BAND, BATTERY	2	2	2	2	
48	36F-28379-00	HOOK	4	4	4	4	

FIG. 22 SIDE COVER

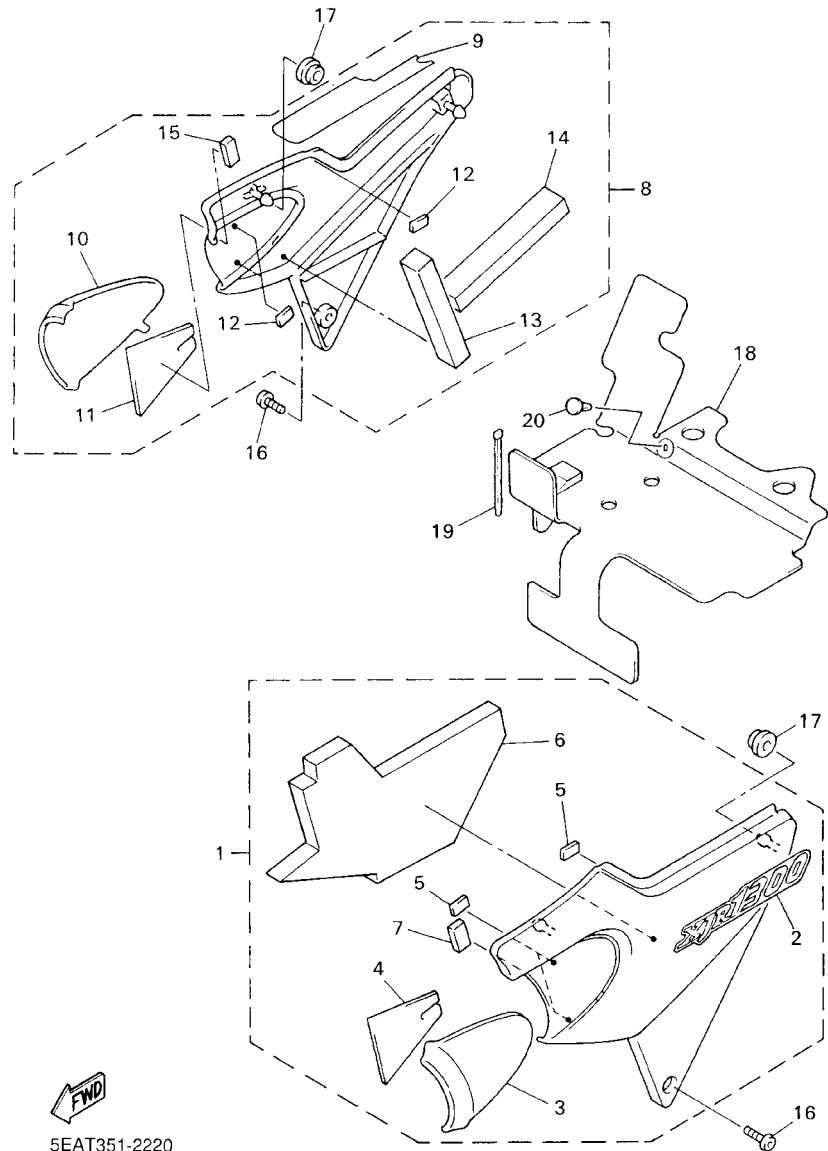

FWD
5EAT351-2220

REF. NO.	PART NO.	DESCRIPTION	5WM1	5WM3	5WM5	5WM6	REMARKS
1	5EA-Y2171-30-2X	COVER, SIDE 1	1	1	1	1	BL2
2	5EA-2173B-20	.EMBLEM	1	1	1	1	
3	5EA-2172A-10	.PANEL 1	1	1	1	1	
4	5EA-21732-00	.SEAL 1	1	1	1	1	
5	51Y-21639-00	.DAMPER 2	3	3	3	3	
6	5EA-2174X-00	.DAMPER	1	1	1	1	
7	21V-21717-00	.DAMPER	1	1	1	1	
8	5EA-Y2172-30-2X	COVER, SIDE 2	1	1	1	1	BL2
9	5EA-2174B-20	.EMBLEM	1	1	1	1	
10	5EA-2172F-10	.PANEL 2	1	1	1	1	
11	5EA-21732-00	.SEAL 1	1	1	1	1	
12	51Y-21639-00	.DAMPER 2	3	3	3	3	
13	5EA-2174Y-00	.DAMPER	1	1	1	1	
14	5EA-21717-00	.DAMPER	1	1	1	1	
15	21V-21717-00	.DAMPER	1	1	1	1	
16	90149-06298	SCREW	2	2	2	2	
17	90480-01558	GROMMET	4	4	4	4	
18	5EA-21732-10	SEAL 1	1	1	1	1	
19	90464-16061	CLAMP	1	1	1	1	
20	90338-06233	PLUG	1	1	1	1	

FIG. 23 REAR ARM. SUSPENSION

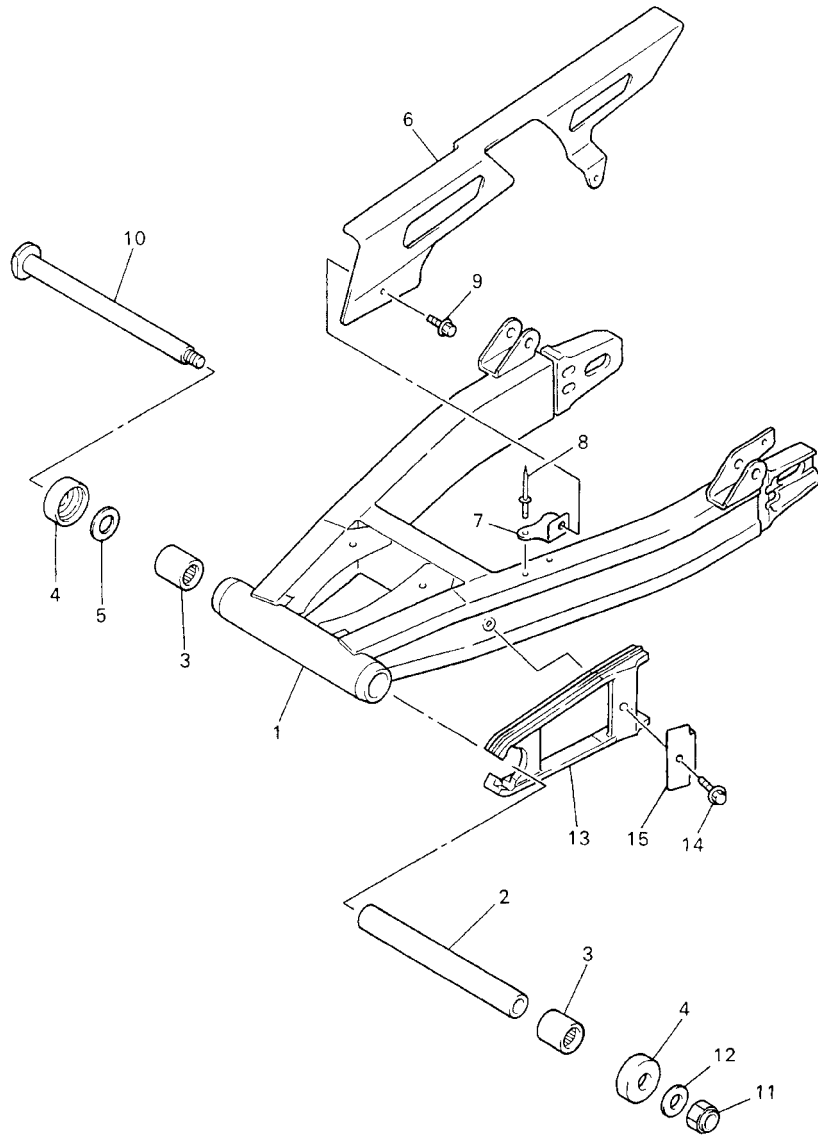

FWD
5EAT351-2230

REF. NO.	PART NO.	DESCRIPTION	5WM1	5WM3	5WM5	5WM6	REMARKS
1	5EA-22110-00	REAR ARM COMP.	1	1	1	1	
2	3FV-22184-00	BUSH	1	1	1	1	
3	93315-42523	BEARING	2	2	2	2	
4	3FV-22128-00	COVER, THRUST 1	2	2	2	2	
5	90201-203F0	WASHER, PLATE	1	1	1	1	UN
6	4KG-22311-00	CASE, CHAIN	1	1	1	1	
7	4KG-22321-00	STAY, CHAIN CASE 1	1	1	1	1	
8	90267-40090	RIVET, BLIND	2	2	2	2	
9	95024-06010	BOLT, FLANGE	2	2	2	2	
10	3GM-22141-01	SHAFT, PIVOT	1	1	1	1	
11	90185-18104	NUT, SELF-LOCKING	1	1	1	1	
12	90201-186M4	WASHER, PLATE	1	1	1	1	
13	4KG-22151-00	SEAL, GUARD	1	1	1	1	
14	95807-06025	BOLT, FLANGE	1	1	1	1	
15	5EA-22149-00	WASHER	1	1	1	1	

FIG. 25 STEERING

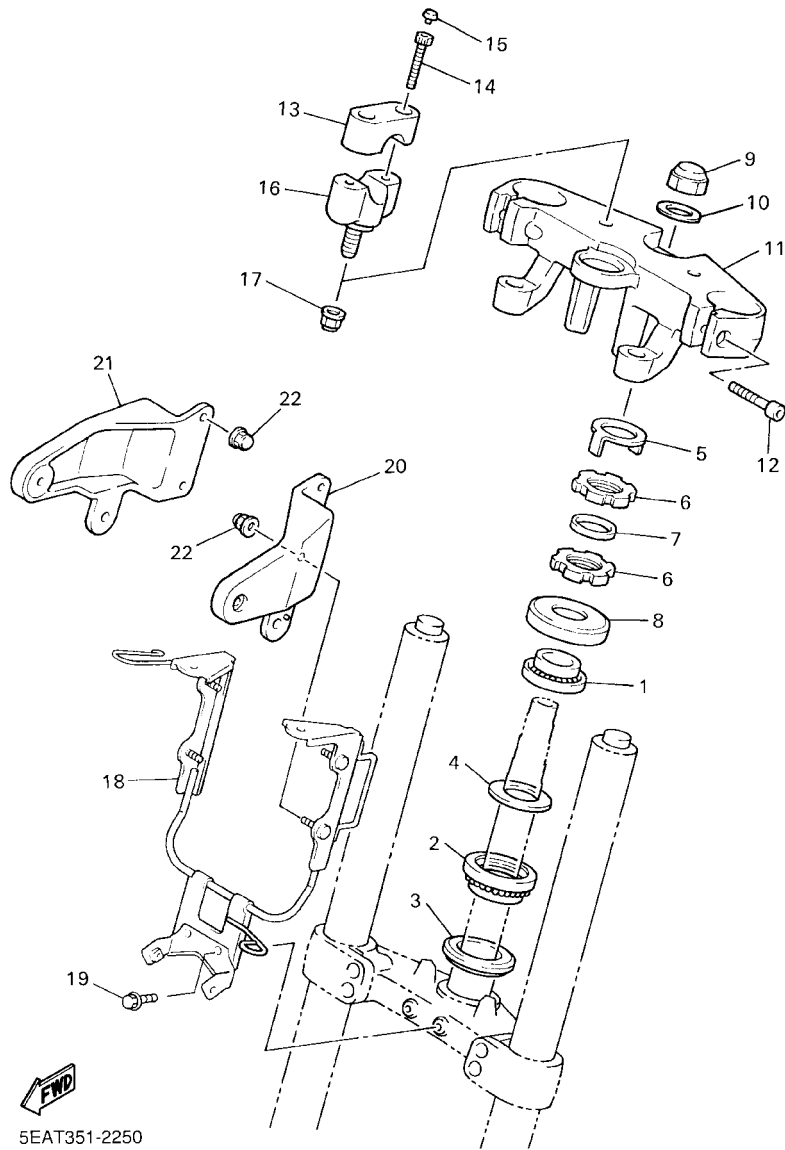

5EAT351-2250

REF. NO.	PART NO.	DESCRIPTION	5WM1	5WM3	5WM5	5WM6	REMARKS
1	93399-99931	BEARING	1	1	1	1	
2	93399-99932	BEARING	1	1	1	1	
3	3FV-23462-00	SEAL, STEERING	1	1	1	1	
4	90202-24190	WASHER, PLATE	1	1	1	1	
5	26H-23418-01	WASHER, SPECIAL	1	1	1	1	
6	90179-25033	NUT	2	2	2	2	
7	90202-26142	WASHER, PLATE	1	1	1	1	
8	1W1-23416-00	COVER, BALL RACE 2	1	1	1	1	
9	90176-22081	NUT, CROWN	1	1	1	1	
10	90201-220T0	WASHER, PLATE	1	1	1	1	
11	4KG-23435-00	CROWN, HANDLE	1	1	1	1	
12	91314-08030	BOLT	2	2	2	2	
13	4H7-23441-00-38	HOLDER, HANDLE UPPER	2	2	2	2	CLP
14	91314-08030	BOLT	4	4	4	4	
15	90338-08163	PLUG	4	4	4	4	
16	5H0-23442-01-38	HOLDER, HANDLE LOWER	2	2	2	2	CLP
17	95607-10200	NUT, U FLANGE	2	2	2	2	
18	5EA-23174-30	STAY, HEADLIGHT	1	1	1	1	
19	95027-06020	BOLT, FLANGE	2	2	2	2	
20	5EA-23121-00	COVER, UPPER 1	1	1	1	1	
21	5EA-23131-00	COVER, UPPER 2	1	1	1	1	
22	90176-06055	NUT, CROWN	4	4	4	4	

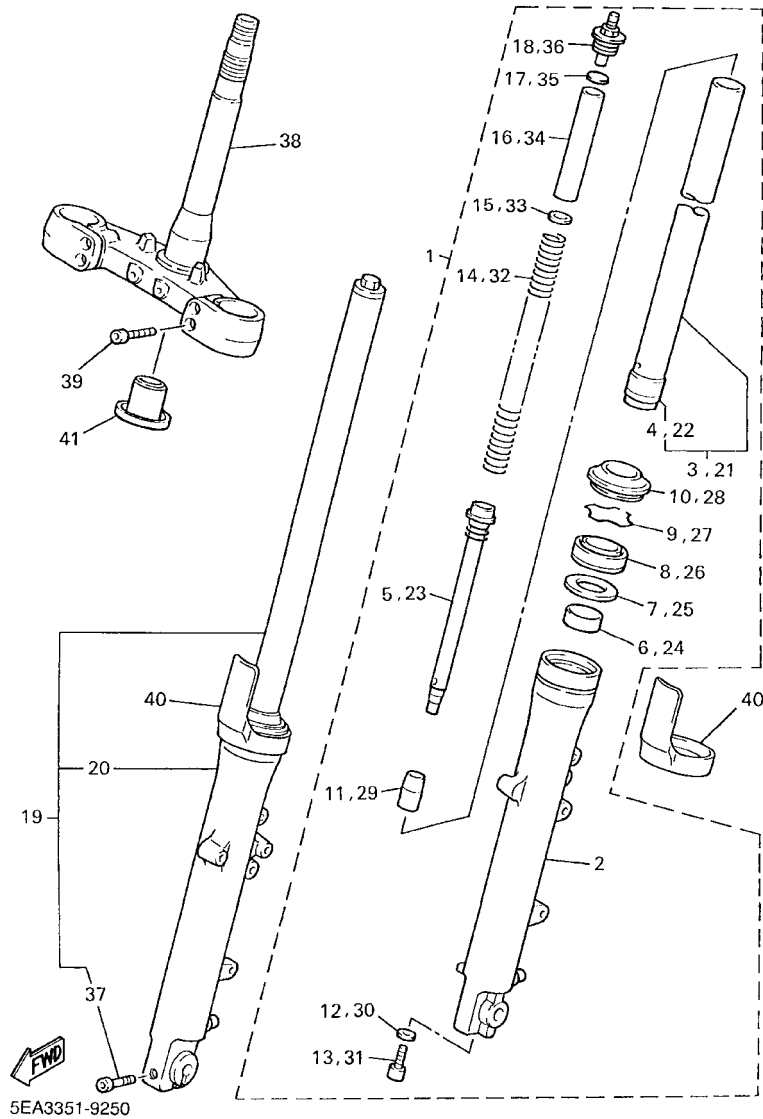
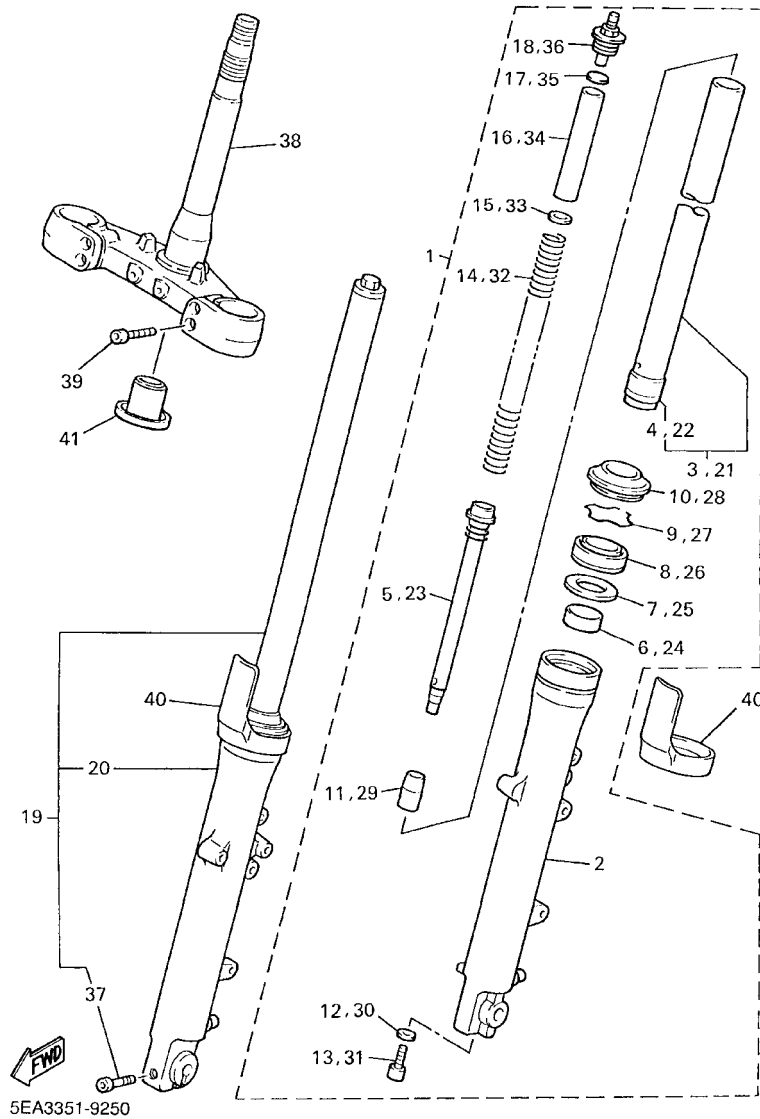

FIG. 26 FRONT FORK

REF. NO.	PART NO.	DESCRIPTION	5WM1	5WM3	5WM5	5WM6	REMARKS
1	5EA-23102-30	FRONT FORK ASSY (L.H)	1	1	1	1	
2	5EA-23126-30	.TUBE, OUTER (LEFT)	1	1	1	1	
3	5EA-23110-30	.INNER TUBE COMP.1	1	1	1	1	
4	5EA-23171-30	..PISTON, FRONT FORK	1	1	1	1	
5	5EA-23170-30	.CYLINDER COMP., FRONT FORK	1	1	1	1	
6	5EB-23125-00	.METAL, SLIDE 1	1	1	1	1	
7	4V4-23146-L0	.WASHER, OIL SEAL	1	1	1	1	
8	4PU-23145-01	.OIL SEAL	1	1	1	1	
9	4V4-23153-L0	.RING, SNAP	1	1	1	1	
10	4PU-23144-00	.SEAL, DUST	1	1	1	1	
11	4YR-23173-00	.SPINDLE, TAPER	1	1	1	1	
12	509-23158-L0	.GASKET	1	1	1	1	
13	278-23181-50	.BOLT, HEXAGON SOCKET HEAD	1	1	1	1	
14	5EA-23141-30	.SPRING, FRONT FORK	1	1	1	1	
15	3LR-23149-00	.WASHER, SPRING UPPER	1	1	1	1	
16	3YF-23118-00	.SPACER	1	1	1	1	
17	3GM-23149-00	.WASHER, SPRING UPPER	1	1	1	1	
18	4PU-23111-20	.BOLT, CAP	1	1	1	1	
19	5EA-23103-30	FRONT FORK ASSY (R.H)	1	1	1	1	
20	5EA-23136-30	.TUBE, OUTER (RIGHT)	1	1	1	1	
21	5EA-23110-30	.INNER TUBE COMP.1	1	1	1	1	
22	5EA-23171-30	..PISTON, FRONT FORK	1	1	1	1	
23	5EA-23170-30	.CYLINDER COMP., FRONT FORK	1	1	1	1	
24	5EB-23125-00	.METAL, SLIDE 1	1	1	1	1	
25	4V4-23146-L0	.WASHER, OIL SEAL	1	1	1	1	
26	4PU-23145-01	.OIL SEAL	1	1	1	1	
27	4V4-23153-L0	.RING, SNAP	1	1	1	1	

FIG. 26 FRONT FORK



REF. NO.	PART NO.	DESCRIPTION	5WM1	5WM3	5WM5	5WM6	REMARKS
28	4PU-23144-00	.SEAL, DUST	1	1	1	1	
29	4YR-23173-00	.SPINDLE, TAPER	1	1	1	1	
30	509-23158-L0	.GASKET	1	1	1	1	
31	278-23181-50	.BOLT, HEXAGON SOCKET HEAD	1	1	1	1	
32	5EA-23141-30	.SPRING, FRONT FORK	1	1	1	1	
33	3LR-23149-00	.WASHER, SPRING UPPER	1	1	1	1	
34	3YF-23118-00	.SPACER	1	1	1	1	
35	3GM-23149-00	.WASHER, SPRING UPPER	1	1	1	1	
36	4PU-23111-20	.BOLT, CAP	1	1	1	1	
37	91314-08040	.BOLT	1	1	1	1	
38	5EA-23340-30	UNDER BRACKET COMP.	1	1	1	1	
39	91317-08025	BOLT	4	4	4	4	
40	4PU-2331G-00	COVER	2	2	2	2	
41	4KM-23123-01	COVER, LOWER 1	1	1	1	1	

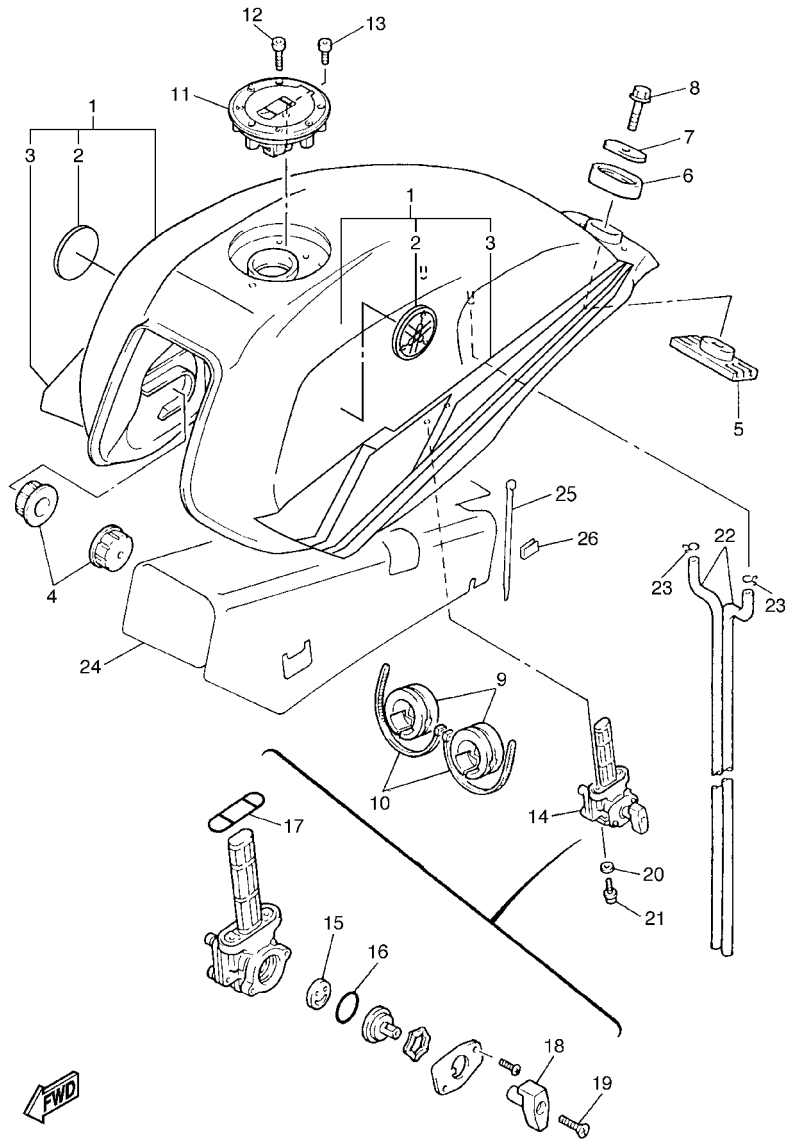

5WM1351-B270

FIG. 27 FUEL TANK

REF. NO.	PART NO.	DESCRIPTION	5WM1	5WM3	5WM5	5WM6	REMARKS
1	5EA-Y2410-G0-08	FUEL TANK COMP.	1		1		BL2
	5EA-Y2410-G0-09	FUEL TANK COMP.	1		1		DPBMC/BL2
	5EA-Y2410-G0-X2	FUEL TANK COMP.		1		1	RYC1/BL2
2	5FY-2411B-00	.TUNING FORK MARK	2		2		
	5FY-2411B-50	.TUNING FORK MARK		2		2	
3	5WM-24240-00	.GRAPHIC SET	1		1		UR FOR BL2
	5WM-24240-10	.GRAPHIC SET	1		1		UR FOR DPBMC
	5WM-24240-20	.GRAPHIC SET		1		1	FOR RYC1
4	2YK-24181-10	DAMPER, LOCATING 1	2	2	2	2	
5	2GH-24184-00	DAMPER, LOCATING 4	1	1	1	1	
6	3Y6-24183-00	DAMPER, LOCATING 3	1	1	1	1	
7	12R-24186-00	WASHER, SPECIAL	1	1	1	1	
8	97007-08030	BOLT	1	1	1	1	
9	4HM-24183-00	DAMPER, LOCATING 3	2	2	2	2	
10	3MA-82591-00	BAND	2	2	2	2	
11	4HM-24602-00	CAP ASSY	1	1	1	1	
12	90110-05112	BOLT, HEXAGON SOCKET HEAD	3	3	3	3	
13	91317-05010	BOLT	1	1	1	1	
14	5EA-24500-01	FUEL COCK ASSY 1	1	1	1	1	
15	3XV-24523-00	.VALVE	1	1	1	1	
16	3XV-24534-00	.SEAL, COCK	1	1	1	1	
17	4X8-24512-00	.O-RING	1	1	1	1	
18	55K-24524-00	.LEVER, COCK	1	1	1	1	
19	98606-04012	.SCREW, OVAL HEAD	1	1	1	1	
20	90202-05193	WASHER, PLATE	2	2	2	2	
21	90149-06008	SCREW	2	2	2	2	
22	90445-105K7	HOSE (L730)	2	2	2	2	

FIG. 28 SEAT

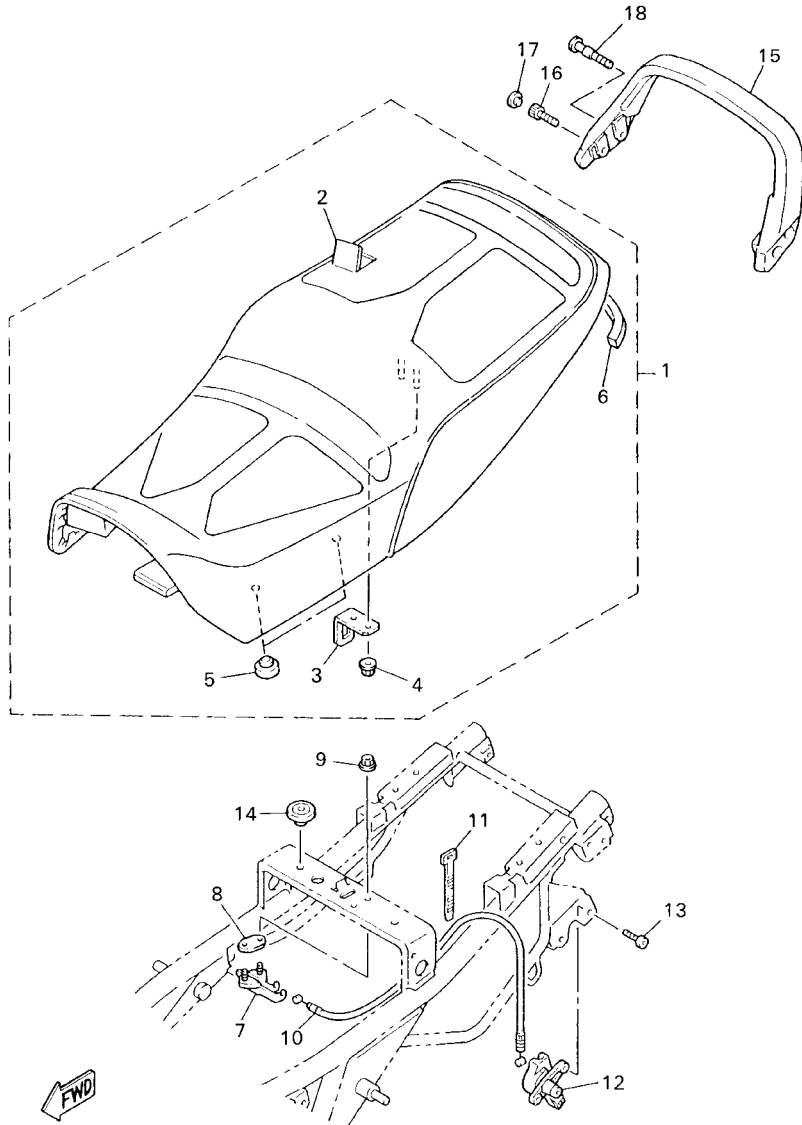

REF. NO.	PART NO.	DESCRIPTION	5WM1	5WM3	5WM5	5WM6	REMARKS
1	5EA-24730-20	DOUBLE SEAT ASSY	1	1	1	1	
2	5EA-2470F-20	.SEAT COVER COMP.	1	1	1	1	
3	4HM-24728-00	.BRACKET, SEAT	1	1	1	1	
4	90179-06635	.NUT	2	2	2	2	
5	22W-24741-00	.PAD, SEAT	4	4	4	4	
6	4BP-24737-00	.DAMPER, SEAT	1	1	1	1	
7	4BP-24780-00	SEAT LOCK ASSY	1	1	1	1	
8	4BP-24792-00	PLATE	1	1	1	1	
9	95707-06500	NUT, FLANGE	2	2	2	2	
10	4KG-2478E-00	CABLE, SEAT LOCK	1	1	1	1	
11	90464-16061	CLAMP	1	1	1	1	
12	3YX-21308-00	HELMET HANGER ASSY	1	1	1	1	
13	90149-06006	SCREW	2	2	2	2	
14	22W-24741-00	PAD, SEAT	2	2	2	2	
15	4KG-24773-00-4B	HANDLE, SEAT	1	1	1	1	BL2
16	91317-08025	BOLT	2	2	2	2	
17	90338-08163	PLUG	2	2	2	2	
18	5EA-21631-00	BOLT 1	2	2	2	2	

FIG. 29 FRONT WHEEL

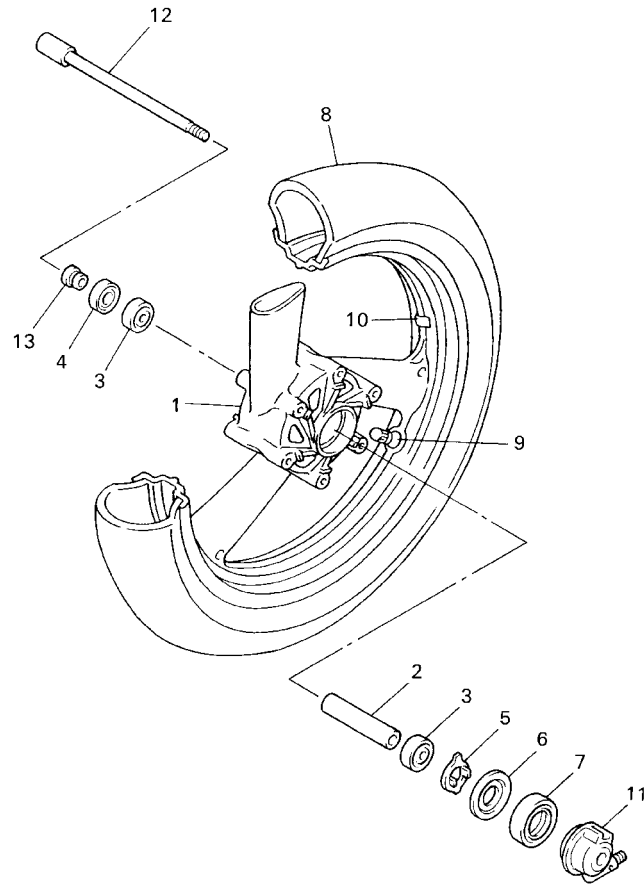

REF. NO.	PART NO.	DESCRIPTION	5WM1	5WM3	5WM5	5WM6	REMARKS
1	4SV-25168-00-33	CAST WHEEL, FRONT	1	1	1	1	YB
2	5EA-25117-00	SPACER, BEARING	1	1	1	1	
3	93306-00420	BEARING (B6004)	2	2	2	2	
4	93106-28043	OIL SEAL	1	1	1	1	
5	4FM-25149-00	CLUTCH, METER	1	1	1	1	
6	341-25846-00	RETAINER, CLUTCH	1	1	1	1	
7	93105-45017	OIL SEAL	1	1	1	1	
8	*	TIRE(120/70ZR17 M/C 58W MACADAM 90X E)	1	1	1	1	UR LM MICHELIN
	94112-17034	TIRE(120/70ZR17 M/C 58W D220F ST M)	1	1	1	1	UR DUNLOP
9	93900-00030	VALVE, RIM (TR412)	1	1	1	1	
10	5MT-25398-00	BALANCER, WHEEL (10G)	1	1	1	1	UR
	5MT-25398-10	BALANCER, WHEEL (20G)	1	1	1	1	UR
	5MT-25398-20	BALANCER, WHEEL (30G)	1	1	1	1	UR
11	4FM-25190-00	GEAR UNIT ASSY	1	1	1	1	
12	4XV-25181-00	AXLE, WHEEL	1	1	1	1	
13	90387-2200T	COLLAR	1	1	1	1	



5EAT351-2290

FIG. 30 FRONT BRAKE CALIPER

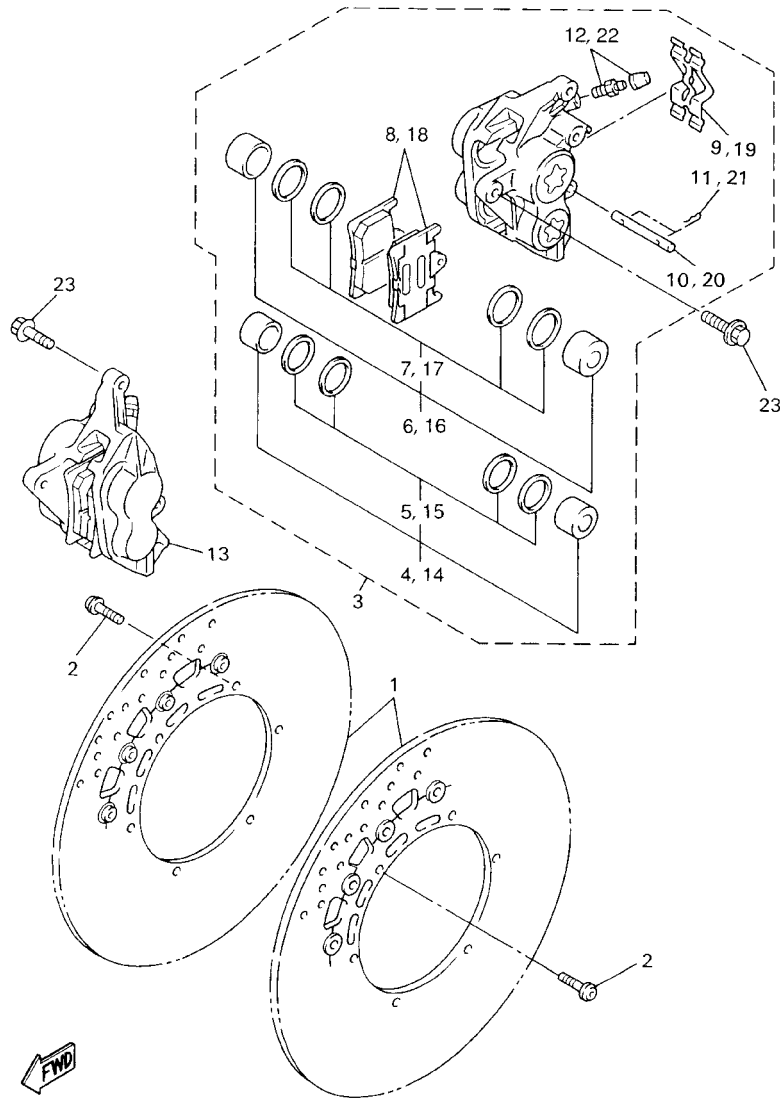

5EAT351-2300

REF. NO.	PART NO.	DESCRIPTION	5WM1	5WM3	5WM5	5WM6	REMARKS
1	5JJ-2581T-10	DISC BRAKE ASSY	2	2	2	2	
2	90109-083G4	BOLT	12	12	12	12	
3	5DM-2580T-00	CALIPER ASSY (LEFT)	1	1	1	1	
4	4SV-W0057-00	.PISTON ASSY, CALIPER	1	1	1	1	
5	3MA-W0047-10	..CALIPER SEAL KIT	1	1	1	1	
6	4SV-W0057-10	.PISTON ASSY, CALIPER	1	1	1	1	
7	3GM-W0047-10	..CALIPER SEAL KIT	1	1	1	1	
8	4SV-W0045-00	.BRAKE PAD KIT	1	1	1	1	
9	4SV-25919-00	.SUPPORT, PAD	1	1	1	1	
10	4SV-25924-00	.PIN, PAD	1	1	1	1	
11	3GM-25925-00	.CLIP	2	2	2	2	
12	1J3-W0048-00	.BLEED SCREW KIT	1	1	1	1	
13	5DM-2580U-00	CALIPER ASSY (RIGHT)	1	1	1	1	
14	4SV-W0057-00	.PISTON ASSY, CALIPER	1	1	1	1	
15	3MA-W0047-10	..CALIPER SEAL KIT	1	1	1	1	
16	4SV-W0057-10	.PISTON ASSY, CALIPER	1	1	1	1	
17	3GM-W0047-10	..CALIPER SEAL KIT	1	1	1	1	
18	4SV-W0045-00	.BRAKE PAD KIT	1	1	1	1	
19	4SV-25919-00	.SUPPORT, PAD	1	1	1	1	
20	4SV-25924-00	.PIN, PAD	1	1	1	1	
21	3GM-25925-00	.CLIP	2	2	2	2	
22	1J3-W0048-00	.BLEED SCREW KIT	1	1	1	1	
23	90105-105A7	BOLT, FLANGE	4	4	4	4	

FIG. 31 REAR WHEEL

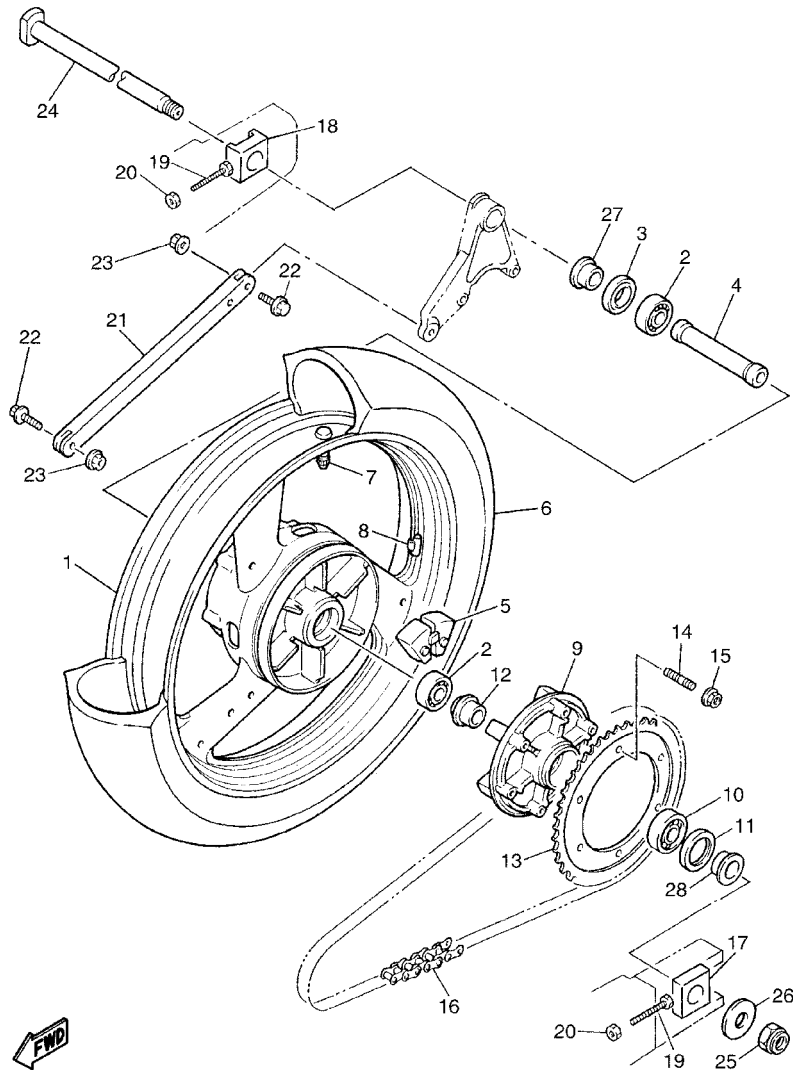

5EAR010-1310

REF. NO.	PART NO.	DESCRIPTION	5WM1	5WM3	5WM5	5WM6	REMARKS
1	5EA-25338-00-33	CAST WHEEL, REAR	1	1	1	1	YB
2	93306-07806	BEARING	2	2	2	2	
3	93106-35042	OIL SEAL	1	1	1	1	
4	90560-28389	SPACER	1	1	1	1	
5	5EA-25364-00	DAMPER	6	6	6	6	
6	*	TIRE(180/55ZR17 M/C 73W MACADAM 90X E)	1	1	1	1	UR LM MICHELIN
	94118-17027	TIRE(180/55ZR17 M/C 73W D220 ST M)	1	1	1	1	UR DUNLOP
7	93900-00030	VALVE, RIM (TR412)	1	1	1	1	
8	5MT-25398-00	BALANCER, WHEEL (10G)	1	1	1	1	UR
	5MT-25398-10	BALANCER, WHEEL (20G)	1	1	1	1	UR
	5MT-25398-20	BALANCER, WHEEL (30G)	1	1	1	1	UR
9	4FM-25366-00	CLUTCH, HUB	1	1	1	1	
10	93306-20644	BEARING	1	1	1	1	
11	93106-40041	OIL SEAL	1	1	1	1	
12	4FM-25377-00	COLLAR, WHEEL	1	1	1	1	
13	5EA-25439-00	SPROCKET, DRIVEN (39T)	1	1	1	1	
14	90116-10575	BOLT, STUD	6	6	6	6	
15	95607-10200	NUT, U FLANGE	6	6	6	6	
16	94582-05112	CHAIN (DID50VA8-112LE)	1	1	1	1	
17	5EA-25388-00	PULLER, CHAIN 1	1	1	1	1	
18	4XV-25389-00	PULLER, CHAIN 2	1	1	1	1	
19	90101-08766	BOLT	2	2	2	2	
20	95307-08600	NUT	2	2	2	2	
21	4FM-25371-10	BAR, TENSION	1	1	1	1	
22	90105-083A9	BOLT, FLANGE	2	2	2	2	
23	95607-08200	NUT, SELF-LOCKING	2	2	2	2	
24	4FM-25381-10	AXLE, WHEEL	1	1	1	1	

FIG. 32 REAR BRAKE CALIPER

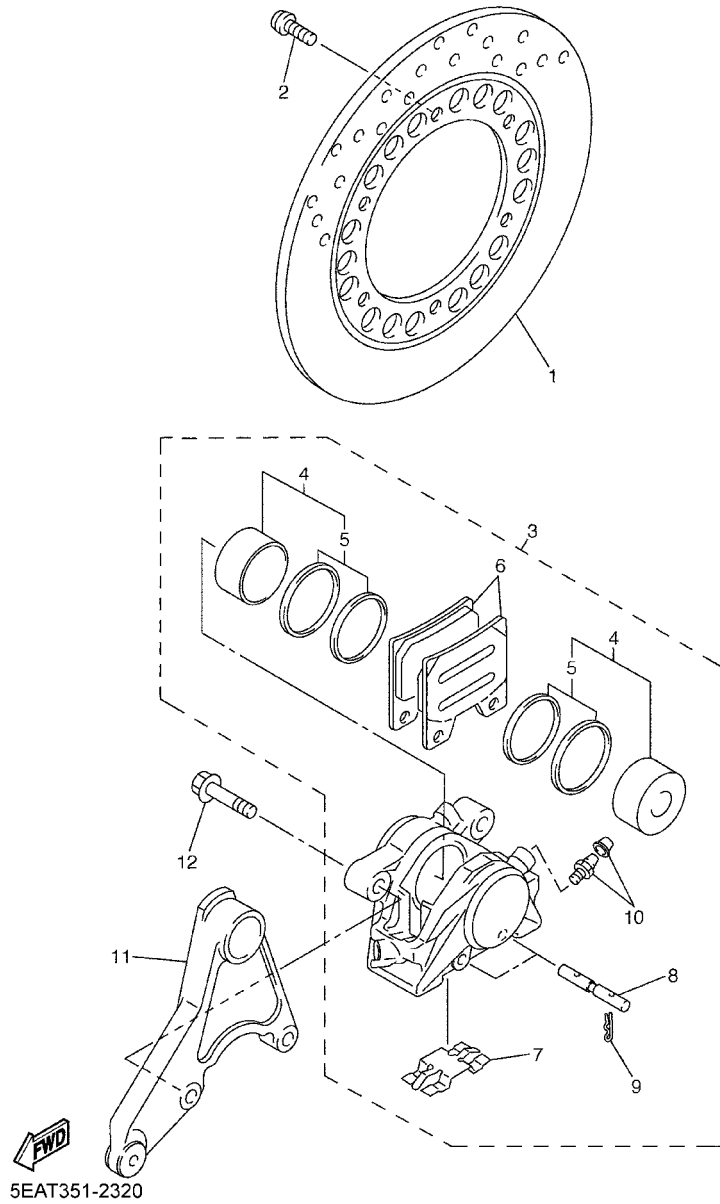

REF. NO.	PART NO.	DESCRIPTION	5WM1	5WM3	5WM5	5WM6	REMARKS
1	3GM-2582W-A0	DISC, REAR BRAKE 2	1	1	1	1	
2	90109-083G4	BOLT	6	6	6	6	
3	5EA-2580W-10	CALIPER ASSY, REAR 2	1	1	1	1	
4	5EA-W0057-50	.PISTON ASSY, CALIPER	1	1	1	1	
5	5EA-W0047-50	..CALIPER SEAL KIT	1	1	1	1	
6	5LV-W0046-50	.BRAKE PAD KIT 2	1	1	1	1	
7	5LV-25919-00	.SUPPORT, PAD	1	1	1	1	
8	5LV-25924-00	.PIN, PAD	2	2	2	2	
9	3GM-25925-00	.CLIP	4	4	4	4	
10	1J3-W0048-00	.BLEED SCREW KIT	2	2	2	2	
11	5EA-25819-00	BRACKET, CALIPER	1	1	1	1	
12	90105-105A0	BOLT, FLANGE	2	2	2	2	

FIG. 33 STEERING HANDLE. CABLE

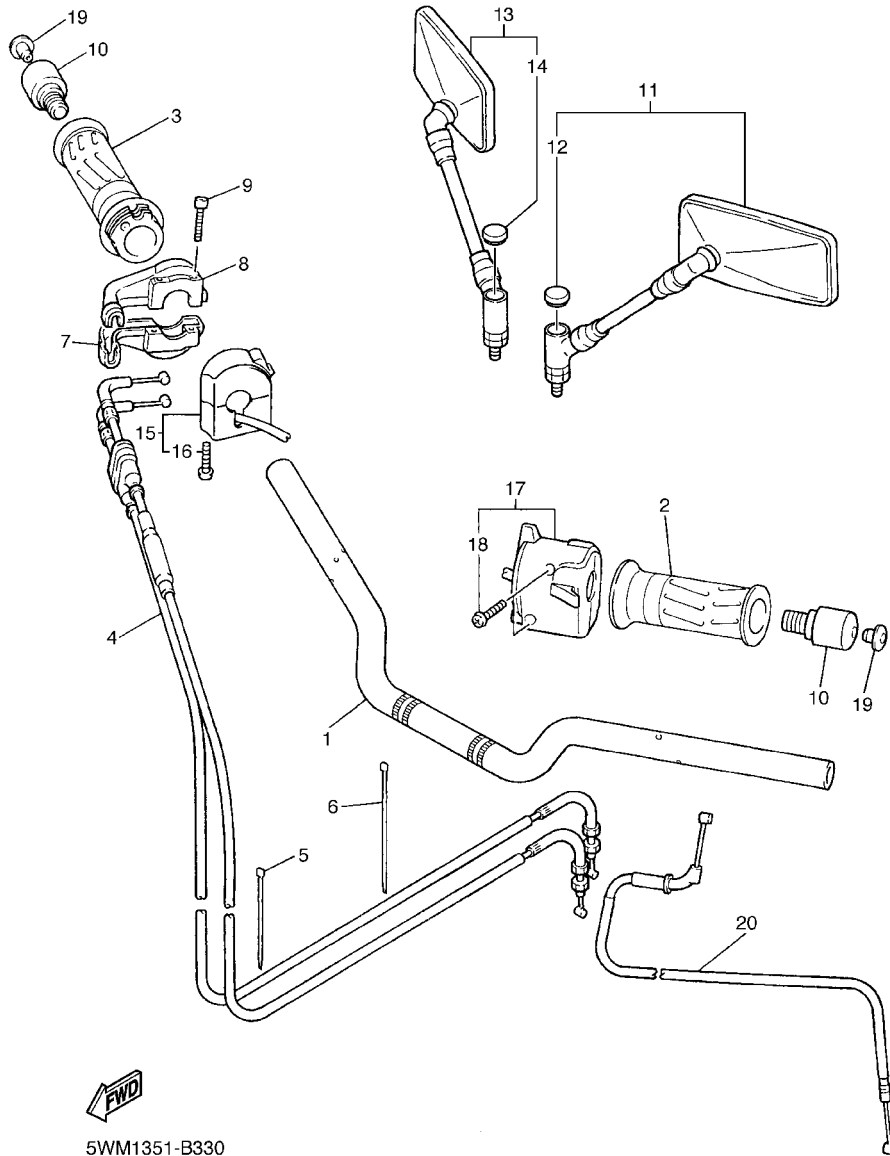

5WM1351-B330

REF. NO.	PART NO.	DESCRIPTION	5WM1	5WM3	5WM5	5WM6	REMARKS
1	5EA-26111-10	HANDLEBAR	1	1	1	1	
2	4YR-26241-01	GRIP (LEFT)	1	1	1	1	
3	4YR-26240-01	GRIP ASSY	1	1	1	1	
4	5EA-26302-10	THROTTLE CABLE ASSY	1	1	1	1	
5	90464-16061	CLAMP	1	1	1	1	
6	1UA-82591-00	BAND	1	1	1	1	
7	4KG-26281-00	CAP, GRIP UPPER	1	1	1	1	
8	3XW-26282-01	CAP, GRIP LOWER	1	1	1	1	
9	91317-05035	BOLT	2	2	2	2	
10	3HX-26246-00	END, GRIP	2	2	2	2	
11	4VR-26280-01	REAR VIEW MIRROR ASSY (LEFT)	1	1	1	1	
12	5PS-26133-00	.CAP	1	1	1	1	
13	4VR-26290-01	REAR VIEW MIRROR ASSY (RIGHT)	1	1	1	1	
14	5PS-26133-00	.CAP	1	1	1	1	
15	4PU-83963-00	SWITCH, HANDLE 3 (RIGHT)	1	1			
	4HM-83975-11	SWITCH, HANDLE 2			1	1	
16	98507-05045	.SCREW, PAN HEAD	2	2			
	98507-05022	.SCREW, PAN HEAD			2	2	
17	5EA-83969-10	SWITCH, HANDLE 5	1	1			
	4UW-83972-00	SWITCH, HANDLE 4			1	1	
18	98507-05025	.SCREW, PAN HEAD	2	2	2	2	
19	4X7-23469-10	CAP, BOLT	2	2	2	2	
20	5EA-26330-00	STARTER CABLE ASSY	1	1	1	1	

FIG. 34 FRONT MASTER CYLINDER

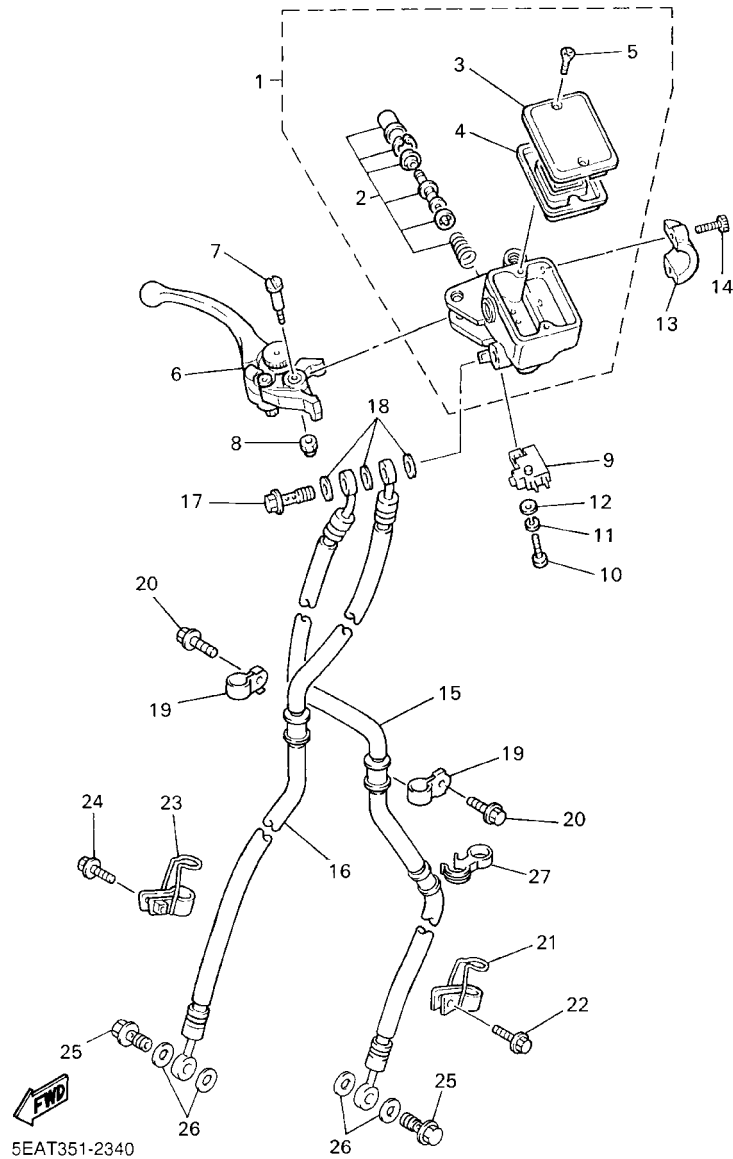

REF. NO.	PART NO.	DESCRIPTION	5WM1	5WM3	5WM5	5WM6	REMARKS
1	5DM-W2587-01	MASTER CYLINDER SUB ASSY	1	1	1	1	
2	5DM-W0041-50	.CYLINDER KIT, MASTER	1	1	1	1	
3	4HM-W2585-01	.RESERVOIR CAP SET	1	1	1	1	
4	4HM-25854-00	.DIAPHRAGM, RESERVOIR	1	1	1	1	
5	98706-04012	.SCREW, FLAT HEAD	2	2	2	2	
6	5EB-83922-01	LEVER 2	1	1	1	1	
7	3FV-2589F-00	BOLT, LEVER	1	1	1	1	
8	95606-06100	NUT, U	1	1	1	1	
9	4HM-83980-00	FRONT STOP SWITCH ASSY	1	1	1	1	
10	98502-04012	SCREW, PAN HEAD	1	1	1	1	
11	92902-04100	WASHER, SPRING	1	1	1	1	
12	92902-04600	WASHER, PLATE	1	1	1	1	
13	4HM-25867-00	BRACKET, MASTER CYLINDER	1	1	1	1	
14	91316-06020	BOLT	2	2	2	2	
15	5EA-25872-30	HOSE, BRAKE 1	1	1	1	1	
16	5EA-25873-20	HOSE, BRAKE 2	1	1	1	1	
17	90401-10160	BOLT, UNION	1	1	1	1	
18	90201-10118	WASHER, PLATE	3	3	3	3	
19	90461-10132	CLAMP	2	2	2	2	
20	95027-06010	BOLT, FLANGE	2	2	2	2	
21	4KG-25887-01	HOLDER, BRAKE HOSE	1	1	1	1	
22	95027-06025	BOLT, FLANGE	1	1	1	1	
23	4KG-25876-01	HOLDER, BRAKE HOSE 2	1	1	1	1	
24	95027-06025	BOLT, FLANGE	1	1	1	1	
25	90401-10159	BOLT, UNION	2	2	2	2	
26	90201-10118	WASHER, PLATE	4	4	4	4	
27	3MA-26279-00	GUIDE, CABLE	1	1	1	1	

FIG. 35 FRONT MASTER CYLINDER 2

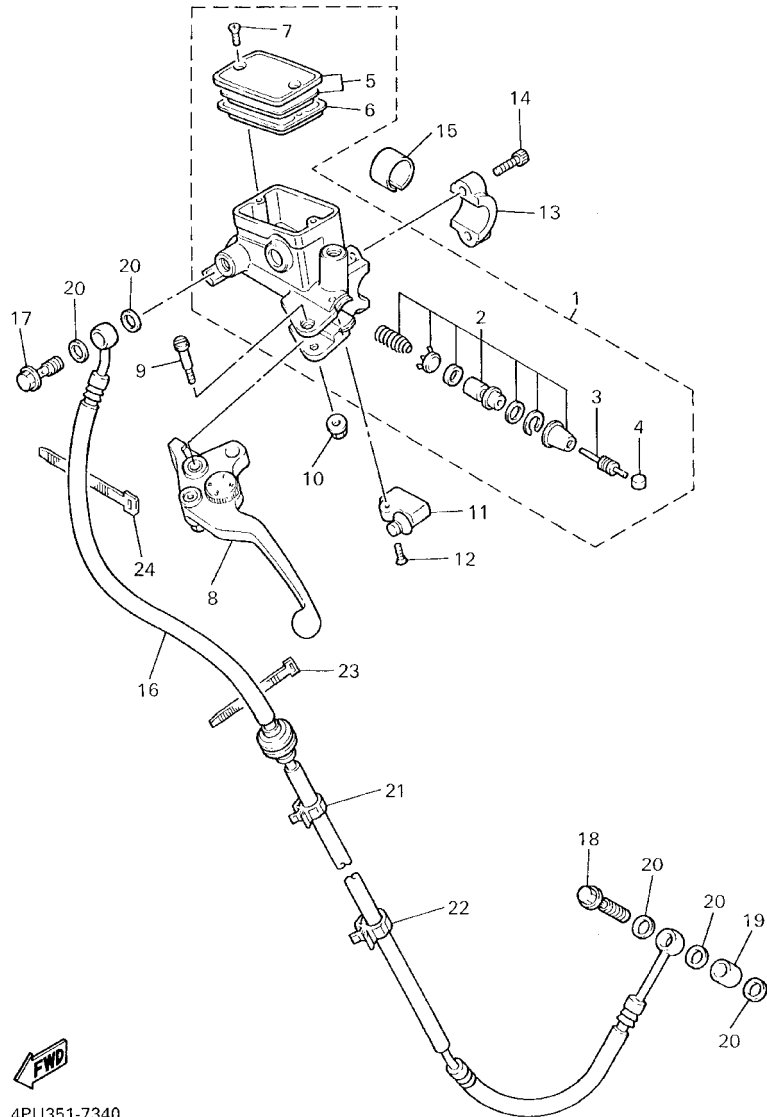

4PU351-7340

REF. NO.	PART NO.	DESCRIPTION	5WM1	5WM3	5WM5	5WM6	REMARKS
1	4KG-W2645-01	MASTER CYLINDER SUB ASSY	1	1	1	1	
2	3GM-W0099-00	.CYLINDER KIT, MASTER (CLUTCH)	1	1	1	1	
3	3GM-26464-00	.ROD, PUSH	1	1	1	1	
4	3GM-26455-00	.BUSH	1	1	1	1	
5	4HM-W2585-01	.RESERVOIR CAP SET	1	1	1	1	
6	4HM-25854-00	.DIAPHRAGM, RESERVOIR	1	1	1	1	
7	98706-04012	.SCREW, FLAT HEAD	2	2	2	2	
8	5EA-83912-00	LEVER 1	1	1	1	1	
9	3FV-2589F-00	BOLT, LEVER	1	1	1	1	
10	95706-06500	NUT, FLANGE	1	1	1	1	
11	3GM-83980-00	FRONT STOP SWITCH ASSY	1	1	1	1	
12	98706-04016	SCREW, FLAT HEAD	1	1	1	1	
13	4KG-25867-00	BRACKET, MASTER CYLINDER	1	1	1	1	
14	91316-06020	BOLT	2	2	2	2	
15	90387-22660	COLLAR	1	1	1	1	
16	4KG-26470-01	HOSE, CLUTCH	1	1	1	1	
17	90401-10159	BOLT, UNION	1	1	1	1	
18	90401-10160	BOLT, UNION	1	1	1	1	
19	90387-1005B	COLLAR	1	1	1	1	
20	90201-10118	WASHER, PLATE	5	5	5	5	
21	90464-10190	CLAMP	1	1	1	1	
22	90464-15192	CLAMP	1	1	1	1	
23	90464-16061	CLAMP	1	1	1	1	
24	437-83936-01	BAND, SWITCH CORD	2	2	2	2	

FIG. 36 STAND, FOOTREST

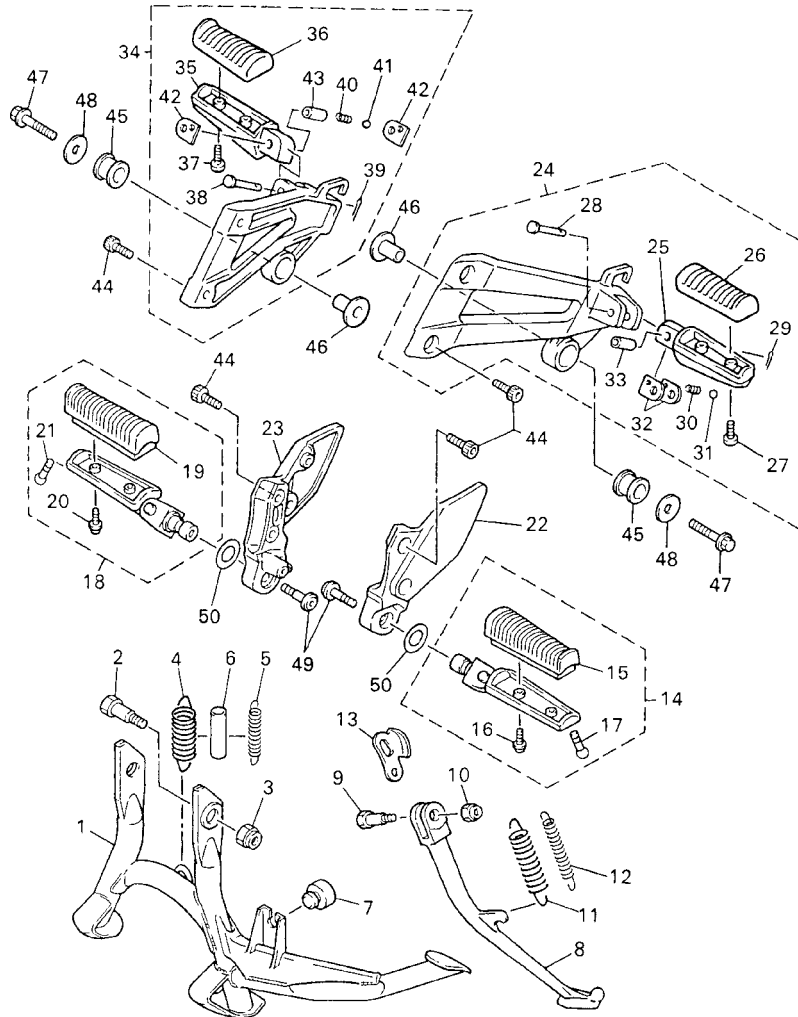

5EAT351-2360

REF. NO.	PART NO.	DESCRIPTION	5WM1	5WM3	5WM5	5WM6	REMARKS
1	5EA-27111-10	STAND, MAIN	1	1	1	1	
2	90109-101E6	BOLT	2	2	2	2	
3	90185-10091	NUT, SELF-LOCKING	2	2	2	2	
4	90506-40529	SPRING, TENSION	1	1	1	1	
5	90506-23528	SPRING, TENSION	1	1	1	1	
6	90445-170K9	HOSE (L60)	1	1	1	1	
7	128-27114-00	STOPPER, MAIN STAND	1	1	1	1	
8	5EA-27311-00	STAND, SIDE	1	1	1	1	
9	90109-104E6	BOLT	1	1	1	1	
10	90185-10037	NUT, SELF-LOCKING	1	1	1	1	
11	90506-26225	SPRING, TENSION	1	1	1	1	
12	90506-18168	SPRING, TENSION	1	1	1	1	
13	4FM-27315-00	LINK, SIDE STAND	1	1	1	1	
14	5EA-27410-00	FRONT FOOTREST ASSY (LEFT)	1	1	1	1	
15	4BP-27413-00	.COVER, FOOTREST	1	1	1	1	
16	90157-05079	.SCREW, PAN HEAD	2	2	2	2	
17	90109-082A4	.BOLT	1	1	1	1	
18	5EA-27420-00	FRONT FOOTREST ASSY (RIGHT)	1	1	1	1	
19	4BP-27413-00	.COVER, FOOTREST	1	1	1	1	
20	90157-05079	.SCREW, PAN HEAD	2	2	2	2	
21	90109-082A4	.BOLT	1	1	1	1	
22	4KG-27442-02	BRACKET 2	1	1	1	1	
23	4KG-27443-02	BRACKET 3	1	1	1	1	
24	5EA-27430-01	REAR FOOTREST ASSY 1	1	1	1	1	
25	4DN-27431-01	.FOOTREST, REAR 1	1	1	1	1	
26	4BP-27413-00	.COVER, FOOTREST	1	1	1	1	
27	90157-05079	.SCREW, PAN HEAD	2	2	2	2	

FIG. 36 STAND, FOOTREST

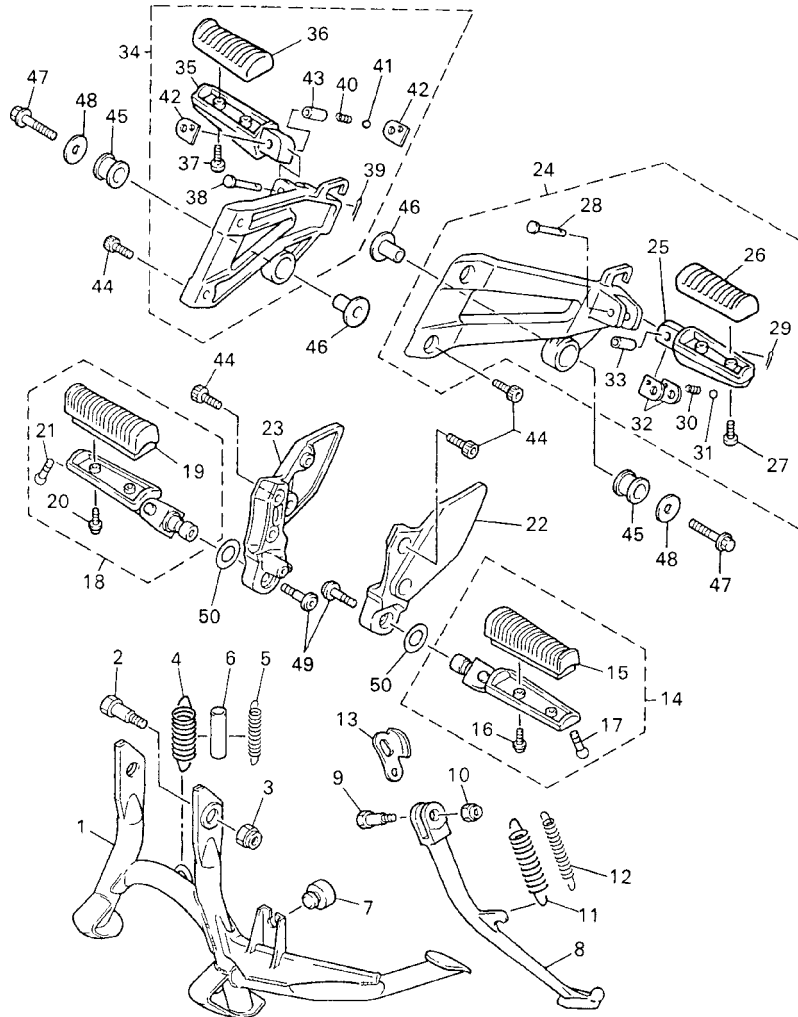

5EAT351-2360

REF. NO.	PART NO.	DESCRIPTION	5WM1	5WM3	5WM5	5WM6	REMARKS
28	91701-06042	.PIN, CLEVIS	1	1	1	1	
29	91401-20012	.PIN, COTTER	1	1	1	1	
30	90501-15001	.SPRING, COMPRESSION	1	1	1	1	
31	93501-04011	.BALL	1	1	1	1	
32	1HX-27437-00	.WASHER, SPECIAL	2	2	2	2	
33	90387-064H8	.COLLAR	1	1	1		
34	5EA-27440-01	REAR FOOTREST ASSY 2	1	1	1	1	
35	4DN-27441-01	.FOOTREST, REAR 2	1	1	1	1	
36	4BP-27413-00	.COVER, FOOTREST	1	1	1	1	
37	90157-05079	.SCREW, PAN HEAD	2	2	2	2	
38	91701-06042	.PIN, CLEVIS	1	1	1	1	
39	91401-20012	.PIN, COTTER	1	1	1	1	
40	90501-15001	.SPRING, COMPRESSION	1	1	1	1	
41	93501-04011	.BALL	1	1	1	1	
42	1HX-27437-00	.WASHER, SPECIAL	2	2	2	2	
43	90387-064H8	.COLLAR	1	1	1	1	
44	90109-081G0	BOLT	8	8	8	8	
45	36Y-27424-00	DAMPER, FOOTREST 2	2	2	2	2	
46	90387-10636	COLLAR	2	2	2	2	
47	90109-100G0	BOLT	2	2	2	2	
48	90201-10669	WASHER, PLATE	2	2	2	2	
49	90109-103A9	BOLT	2	2	2	2	
50	90206-17084	WASHER, WAVE	2	2	2	2	

FIG. 37 REAR MASTER CYLINDER

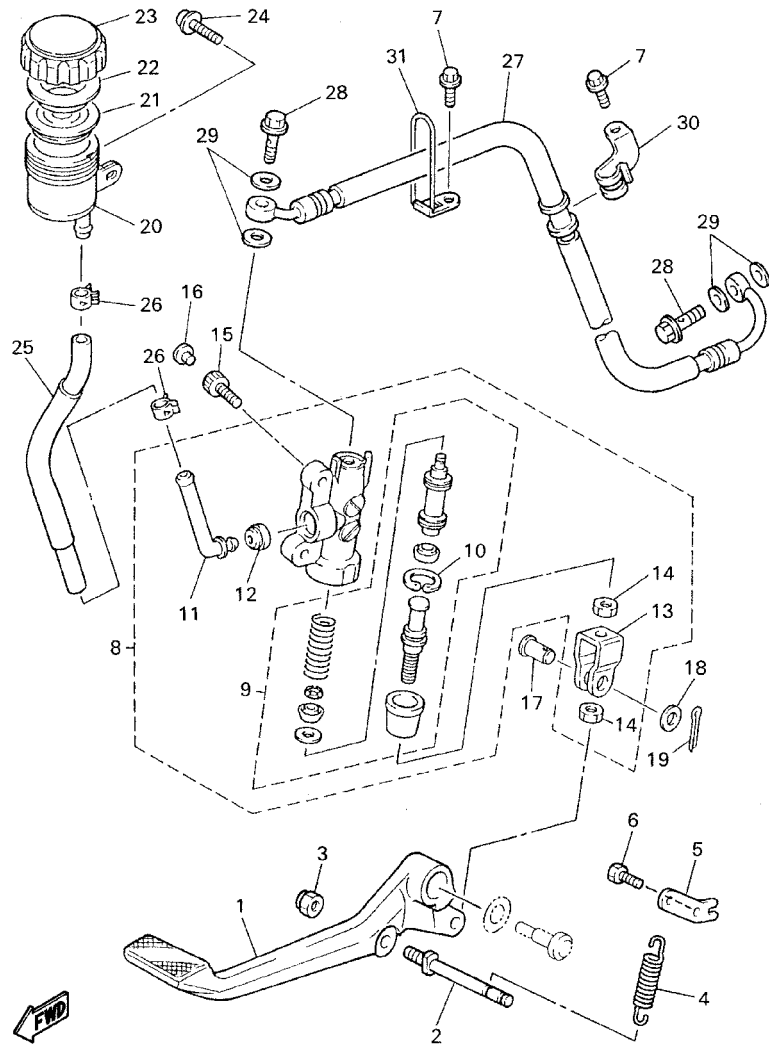

5EAR010-1370

REF. NO.	PART NO.	DESCRIPTION	5WM1	5WM3	5WM5	5WM6	REMARKS
1	4KG-27211-00	PEDAL, BRAKE	1	1	1	1	
2	4KG-27813-00	PIN, PEDAL CRANK	1	1	1	1	
3	95604-08100	NUT, U	1	1	1	1	
4	90506-20377	SPRING, TENSION	1	1	1	1	
5	4KG-27432-00	BRACKET 1	1	1	1	1	
6	97007-06012	BOLT	1	1	1	1	
7	95027-06010	BOLT, FLANGE	2	2	2	2	
8	4BP-2583V-01	RR. MASTER CYLINDER ASSY.	1	1	1	1	
9	4BP-W0042-50	.CYLINDER KIT, MASTER	1	1	1	1	
10	3LN-2585G-00	.CIRCLIP	1	1	1	1	
11	4BP-2582A-00	.JOINT	1	1	1	1	
12	4BP-2585F-00	.BUSH	1	1	1	1	
13	4BP-27222-01	.JOINT	1	1	1	1	
14	90170-08010	.NUT	2	2	2	2	
15	91314-08020	BOLT	2	2	2	2	
16	90338-08163	PLUG	2	2	2	2	
17	90240-08124	PIN, CLEVIS	1	1	1	1	
18	90201-08083	WASHER, PLATE	1	1	1	1	
19	91401-20012	PIN, COTTER	1	1	1	1	
20	31A-25894-01	TANK, RESERVOIR	1	1	1	1	
21	360-25854-01	DIAPHRAGM, RESERVOIR	1	1	1	1	
22	2GU-25855-00	BUSH,DIAPHRAGM	1	1	1	1	
23	2KF-25852-50	CAP, RESERVOIR	1	1	1	1	
24	90159-06056	SCREW, WITH WASHER	1	1	1	1	
25	4KG-25895-00	HOSE, RESERVOIR	1	1	1	1	
26	90467-14057	CLIP	2	2	2	2	
27	5EA-2581K-00	HOSE, BRAKE 5	1	1	1	1	

FIG. 37 REAR MASTER CYLINDER

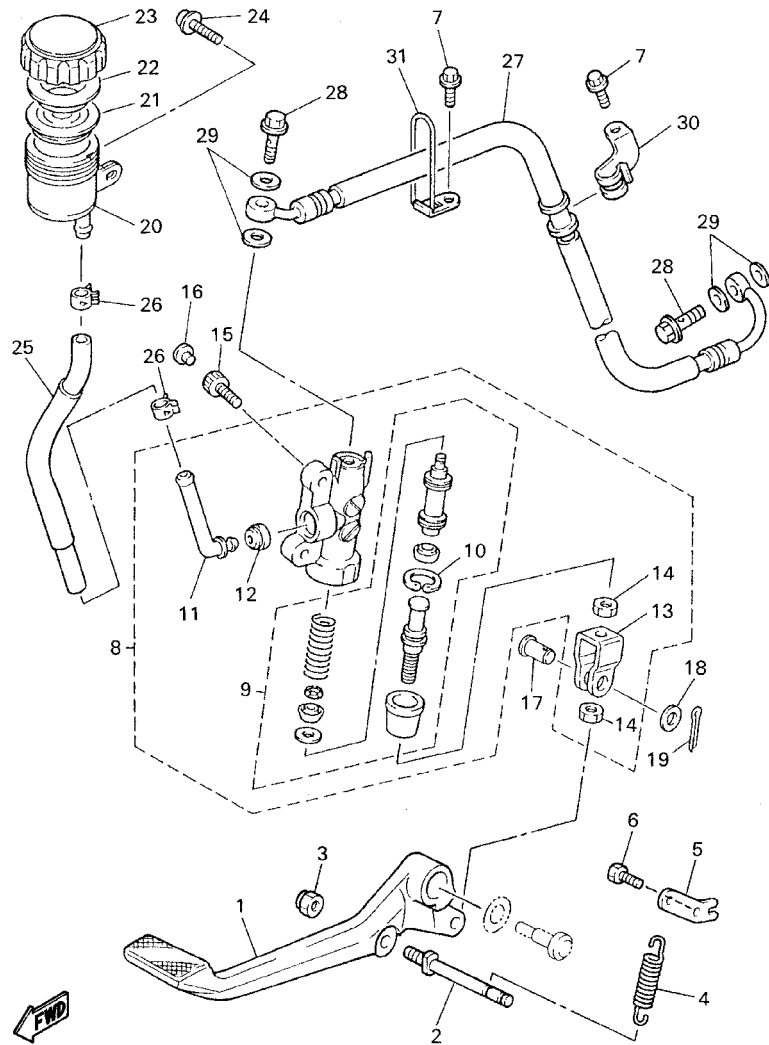

5EAR010-1370

REF. NO.	PART NO.	DESCRIPTION	5WM1	5WM3	5WM5	5WM6	REMARKS
28	90401-10159	BOLT, UNION	2	2	2	2	
29	90201-10118	WASHER, PLATE	4	4	4	4	
30	4FM-25876-01	HOLDER, BRAKE HOSE 2	1	1	1	1	
31	4BH-25886-02	HOLDER, BRAKE HOSE	1	1	1	1	

FIG. 38 GENERATOR

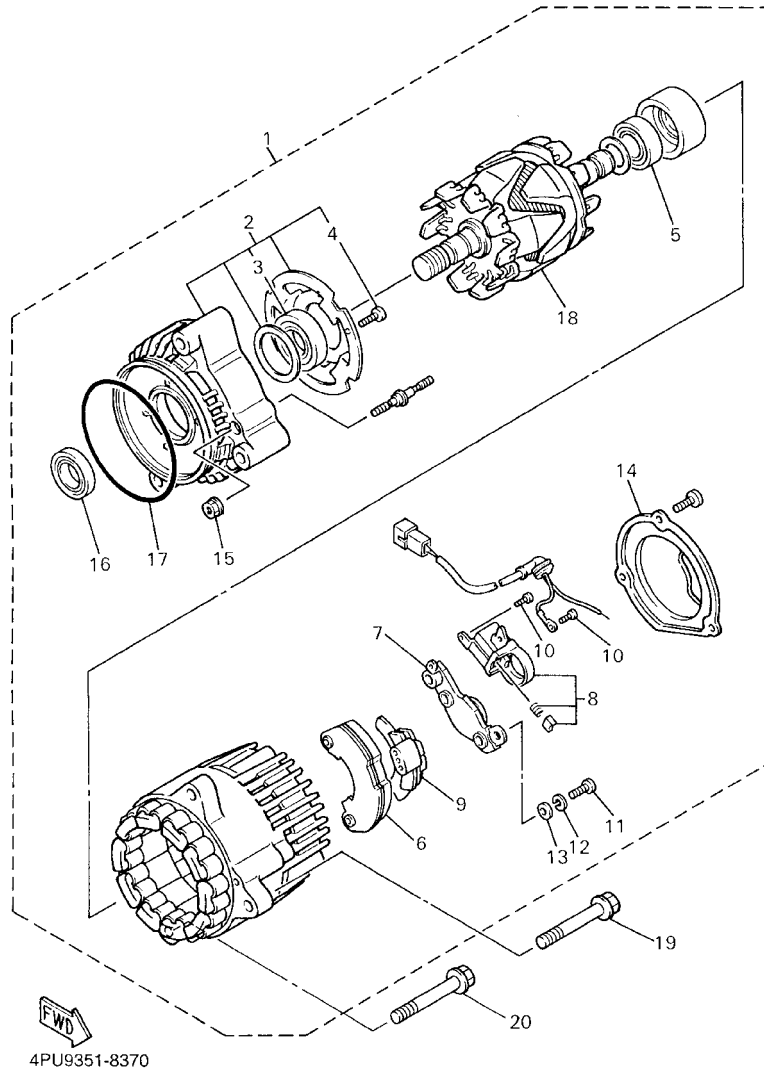

REF. NO.	PART NO.	DESCRIPTION	5WM1	5WM3	5WM5	5WM6	REMARKS
1	5EA-81600-00	A.C. GENERATOR ASSY	1		1		
	4KG-81600-00	A.C. GENERATOR ASSY		1		1	
2	4KG-81634-00	.STATOR ASSY	1	1	1	1	
3	4BH-81643-00	..BEARING	1	1	1	1	
4	4BH-81645-00	..SCREW	4	4	4	4	
5	4BH-81643-10	.BEARING	1	1	1	1	
6	4BH-81970-00	.RECTIFIER ASSY	1	1	1	1	
7	36Y-81910-50	.VOLTAGE REGULATOR ASSY	1	1	1	1	
8	3FV-81619-00	.BRUSH HOLDER ASSY	1	1	1	1	
9	4BH-81972-00	.COVER, RECTIFIER	1	1	1	1	
10	3FV-81645-00	.SCREW	2	2	2	2	
11	98501-05018	.SCREW, PAN HEAD	3	3	3	3	
12	92901-05100	.WASHER, SPRING	3	3	3	3	
13	92901-05600	.WASHER, PLATE	3	3	3	3	
14	4KM-81604-00	.COVER ASSY	1		1		
	4BH-81604-00	.COVER ASSY		1		1	
15	95702-05500	.NUT, FLANGE	2	2	2	2	
16	36Y-81638-50	.OIL SEAL	1	1	1	1	
17	2KT-81642-50	.O-RING	1	1	1	1	
18	4BH-81660-00	.ROTOR ASSY	1	1	1	1	
19	95814-08065	BOLT, FLANGE	2		2		
	90105-084A1	BOLT, FLANGE		2		2	
20	90105-08776	BOLT, FLANGE	1		1		
	90105-084A9	BOLT, FLANGE		1		1	

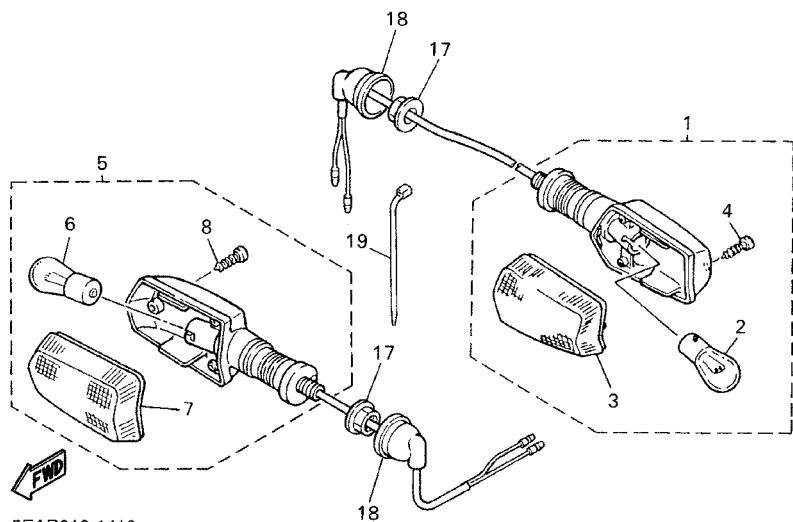
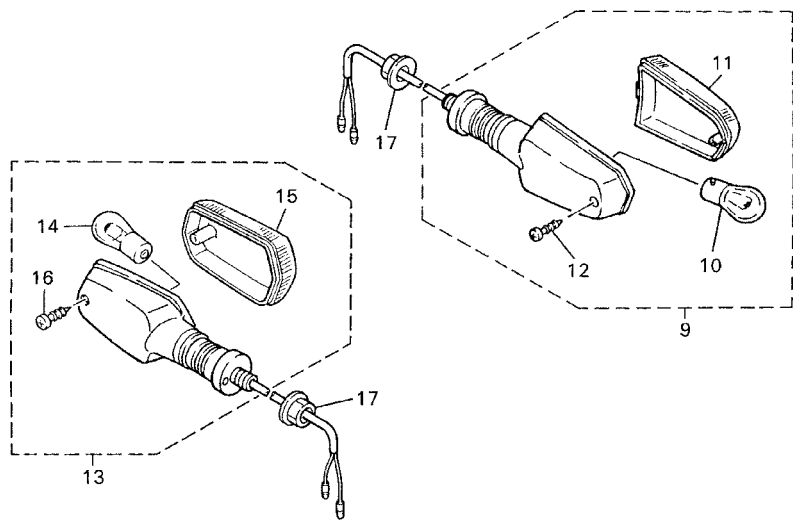
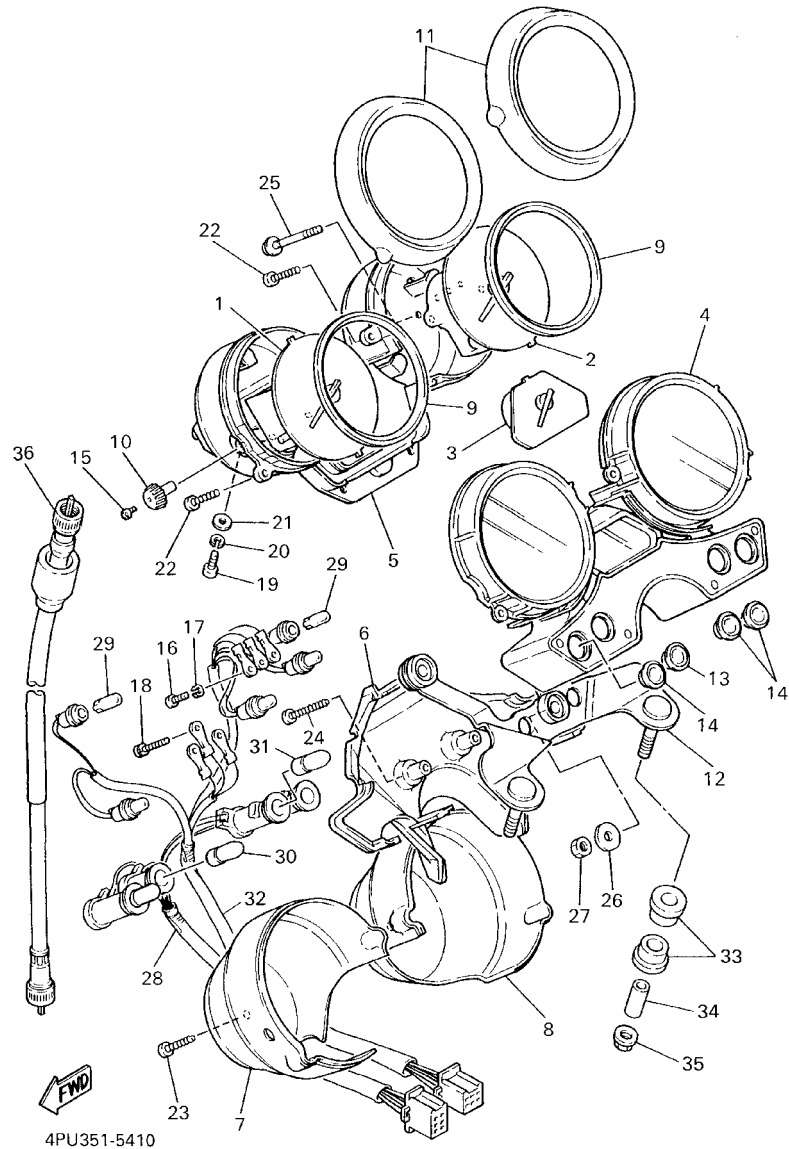

FIG. 41 FLASHER LIGHT

REF. NO.	PART NO.	DESCRIPTION	5WM1	5WM3	5WM5	5WM6	REMARKS
1	4PU-83310-00	FRONT FLASHER LIGHT ASSY 1	1	1	1	1	
2	306-83311-40	.BULB, FLASHER (12V-21W)	1	1	1	1	
3	51L-83332-01	.LENS, FLASHER	1	1	1	1	
4	97701-40620	.SCREW, TAPPING	1	1	1	1	
5	4PU-83320-00	FRONT FLASHER LIGHT ASSY 2	1	1	1	1	
6	306-83311-40	.BULB, FLASHER (12V-21W)	1	1	1	1	
7	51L-83342-01	.LENS, FLASHER 2	1	1	1	1	
8	97701-40620	.SCREW, TAPPING	1	1	1	1	
9	4PU-83330-00	REAR FLASHER LIGHT ASSY 1	1	1	1	1	
10	306-83311-40	.BULB, FLASHER (12V-21W)	1	1	1	1	
11	1VU-83332-00	.LENS, FLASHER	1	1	1	1	
12	97701-40620	.SCREW, TAPPING	1	1	1	1	
13	4PU-83340-00	FLASHER LIGHT ASSY 2	1	1	1	1	
14	306-83311-40	.BULB, FLASHER (12V-21W)	1	1	1	1	
15	1VU-83342-00	.LENS, FLASHER 2	1	1	1	1	
16	97701-40620	.SCREW, TAPPING	1	1	1	1	
17	95707-12500	NUT, FLANGE	4	4	4	4	
18	18G-83365-00	CAP	2	2	2	2	
19	90464-13077	CLAMP	1	1	1	1	

FIG. 42 METER



REF. NO.	PART NO.	DESCRIPTION	5WM1	5WM3	5WM5	5WM6	REMARKS
1	5EA-83570-60	SPEEDOMETER ASSY	1	1	1	1	FOR GBR
	5EA-83570-70	SPEEDOMETER ASSY	1	1			
2	5EA-83540-20	TACHOMETER ASSY	1	1	1	1	
3	4HM-85750-00	FUEL METER ASSY	1	1	1	1	
4	5EA-8353E-20	CASE, METER UPPER	1	1	1	1	
5	4PU-8353F-00	CASE, METER LOWER	1	1	1	1	
6	4HM-83559-00	COVER, METER	1	1	1	1	
7	4HM-83507-00	COVER, SPEEDOMETER	1	1	1	1	
8	4HM-83508-00	COVER, TACHOMETER	1	1	1	1	
9	4HM-8353L-00	REFLECTOR	2	2	2	2	
10	12R-83578-00	KNOB, TRIP METER	1	1	1	1	
11	4HM-83506-00	RING, METER COVER	2	2	2	2	
12	4KG-83519-00	BRACKET, METER	1	1	1	1	
13	4HM-83532-20	LENS, PILOT	1	1	1	1	
14	4HM-83532-30	LENS, PILOT	3	3	3	3	
15	90157-02031	SCREW, PAN HEAD	1	1	1	1	
16	98507-03010	SCREW, PAN HEAD	3	3	3	3	
17	92907-03100	WASHER, SPRING	3	3	3	3	
18	90159-03102	SCREW, WITH WASHER	3	3	3	3	
19	98507-04030	SCREW	2	2	2	2	
20	92907-04100	WASHER, SPRING	2	2	2	2	
21	92907-04600	WASHER	2	2	2	2	
22	97707-40516	SCREW, TAPPING	4	4	4	4	
23	97707-40014	SCREW, TAPPING	2	2	2	2	
24	97707-40030	SCREW, TAPPING	2	2	2	2	
25	90167-04057	SCREW, TAPPING	2	2	2	2	
26	1E6-83524-60	WASHER, SPECIAL	3	3	3	3	

FIG. 43 HEADLIGHT

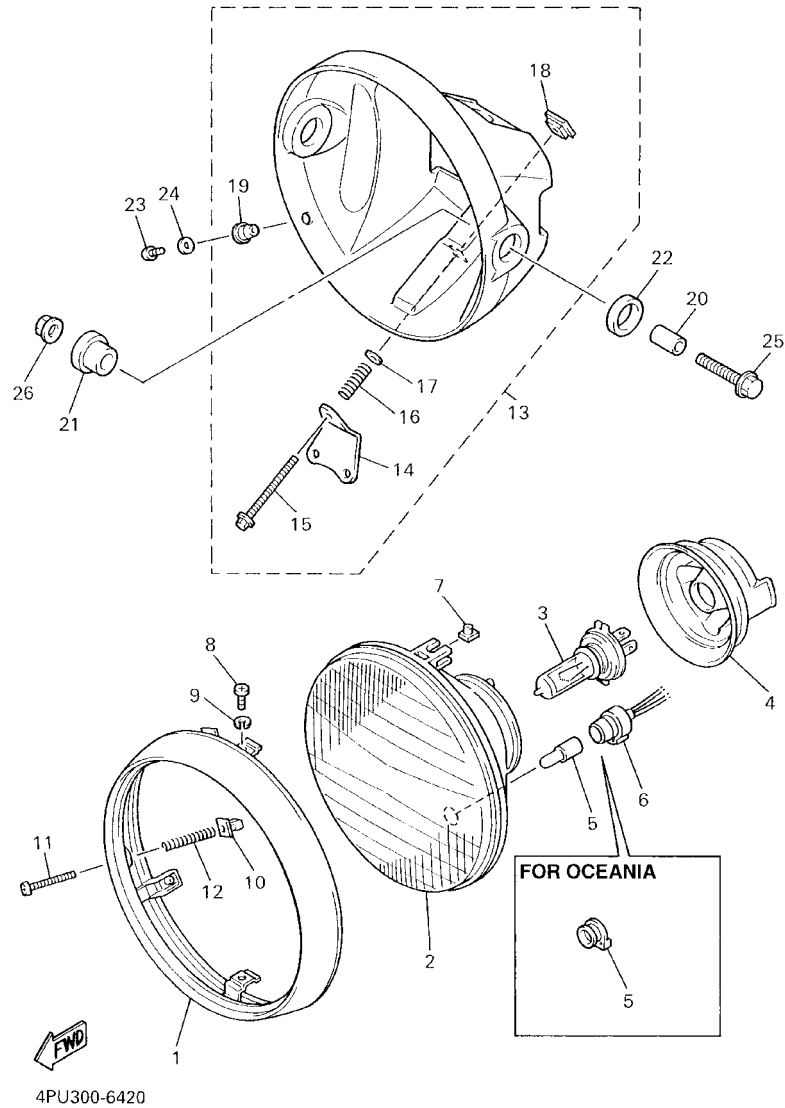

REF. NO.	PART NO.	DESCRIPTION	5WM1	5WM3	5WM5	5WM6	REMARKS
1	4KG-84315-00	RIM, HEADLIGHT	1	1	1	1	
2	4PU-84320-00	LENS ASSY	1	1			
	5EA-84320-00	LENS ASSY	1	1			FOR GBR,ZAF
	4KG-84320-00	LENS ASSY			1	1	
3	2F9-84314-00	BULB (12V-60/55W)	1	1	1	1	(H4)HALOGEN
4	4KG-84397-00	COVER, SOCKET	1	1	1	1	
5	4E2-84347-00	BULB (12V-4W)	1	1			
	4KG-84154-00	GROMMET			1	1	
6	4PU-84346-00	SOCKET, PILOT LIGHT	1	1			
7	4KG-84334-00	NUT, ADJUSTING	2	2	2	2	
8	4KG-84365-00	SCREW	2	2	2	2	
9	92902-06100	WASHER, SPRING	2	2	2	2	
10	47J-84334-00	NUT, ADJUSTING	1	1	1	1	
11	4KG-84331-00	SCREW, RIM ADJUSTING	1	1	1	1	
12	4KG-84332-00	SPRING, SCREW	1	1	1	1	
13	4KG-84330-00	BODY ASSY	1	1	1	1	
14	4KG-84318-00	.STAY, HEADLIGHT 1	1	1	1	1	
15	4KG-8433E-00	.SCREW, ADJUSTING	1	1	1	1	
16	4KG-84335-00	.SPRING	1	1	1	1	
17	4KG-84344-00	.WASHER, PLAIN	1	1	1	1	
18	4KG-84326-00	.NUT	1	1	1	1	
19	5G2-84333-00	.SCREW	2	2	2	2	
20	90387-0804N	COLLAR	2	2	2	2	
21	4KG-84366-00	DAMPER, HEADLIGHT 1	2	2	2	2	
22	4KG-84367-00	DAMPER, HEADLIGHT 2	2	2	2	2	
23	98507-05016	SCREW	2	2	2	2	
24	92907-05600	WASHER, PLATE	2	2	2	2	

FIG. 44 TAILLIGHT

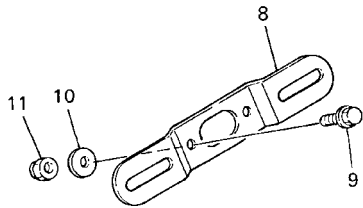
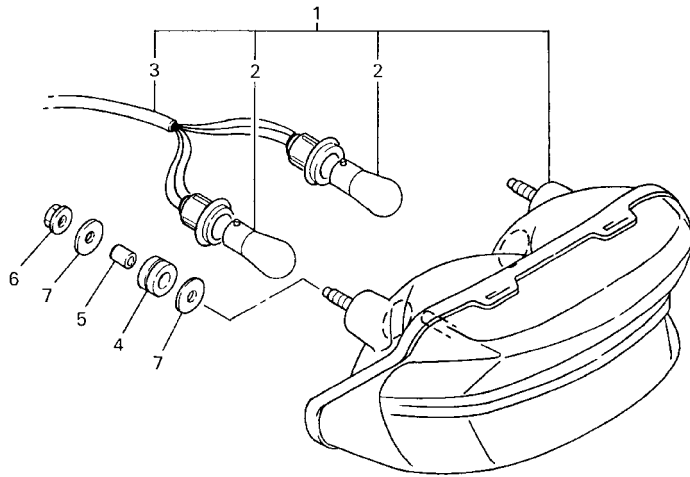

REF. NO.	PART NO.	DESCRIPTION	5WM1	5WM3	5WM5	5WM6	REMARKS
1	5EA-84710-10	TAILLIGHT UNIT ASSY	1	1	1	1	
2	36Y-84714-40	.BULB, TAILLIGHT (12V-21/5W)	2	2	2	2	
3	4HM-84735-00	.CORD ASSY	1	1	1	1	
4	90480-18276	GROMMET	3	3	3	3	
5	90387-07674	COLLAR	3	3	3	3	
6	95707-06500	NUT, FLANGE	3	3	3	3	
7	90201-06380	WASHER, PLATE	6	6	6	6	
8	3YF-84751-00	BRACKET, LICENSE	1	1	1	1	
9	95027-06016	BOLT, FLANGE	2	2	2	2	
10	90201-06380	WASHER, PLATE	2	2	2	2	
11	95607-06100	NUT, U	2	2	2	2	

5EA1010-8430

FIG. 45 ELECTRICAL 1

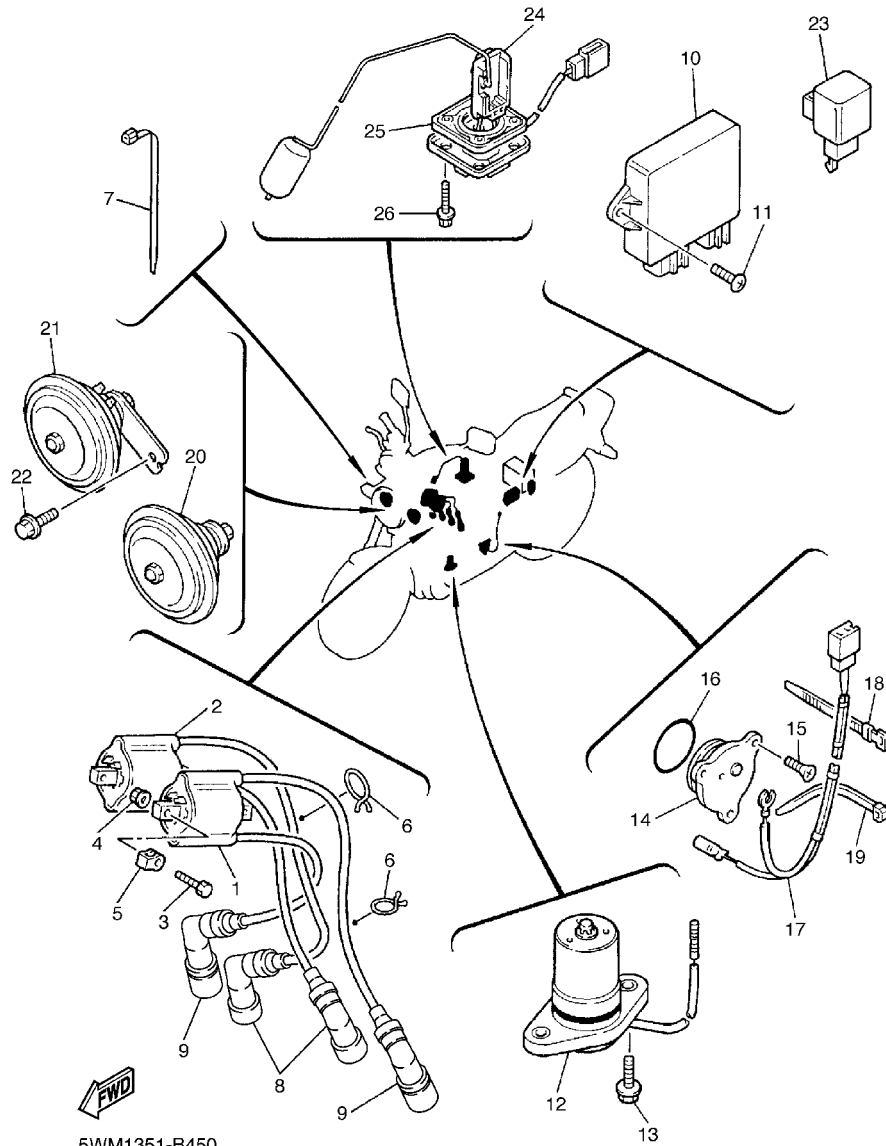

5WM1351-B450

REF. NO.	PART NO.	DESCRIPTION	5WM1	5WM3	5WM5	5WM6	REMARKS
1	5EA-82310-10	IGNITION COIL ASSY	1	1	1	1	
2	5EA-82320-10	IGNITION COIL ASSY	1	1	1	1	
3	97080-06070	BOLT	2	2	2	2	
4	95707-06500	NUT, FLANGE	2	2	2	2	
5	4BR-82317-00	DAMPER, IGNITION COIL	4	4	4	4	
6	90464-16039	CLAMP	2	2	2	2	
7	90464-13073	CLAMP	1	1	1	1	
8	3NS-82370-00	PLUG CAP ASSY	2	2	2	2	
9	5UX-82370-00	PLUG CAP ASSY	2	2	2	2	
10	5EA-82305-40	IGNITOR UNIT ASSY	1	1	1	1	
11	98907-06012	SCREW, BIND	2	2	2	2	
12	5G2-85720-00	OIL LEVEL GAUGE ASSY	1	1	1	1	
13	95027-06016	BOLT, FLANGE	2	2	2	2	
14	1L9-82540-00	NEUTRAL SWITCH ASSY	1	1	1	1	
15	90149-05321	SCREW	3	3	3	3	
16	93210-29196	O-RING	1	1	1	1	
17	4KG-82509-00	WIRE, SUB LEAD	1	1	1	1	
18	90465-10098	CLAMP	1	1	1	1	
19	90464-13077	CLAMP	1	1	1	1	
20	4KG-83371-20	HORN	1	1	1	1	
21	4KG-83371-30	HORN	1	1	1	1	
22	95807-06012	BOLT, FLANGE	2	2	2	2	
23	3GM-83350-01	FLASHER RELAY ASSY	1	1	1	1	
24	4KG-85752-01	SENDER UNIT ASSY, FUEL METER	1	1	1	1	
25	5G3-85753-00	GASKET, SENDER UNIT	1	1	1	1	
26	90119-05071	BOLT, WITH WASHER	4	4	4	4	

FIG. 46 ELECTRICAL 2

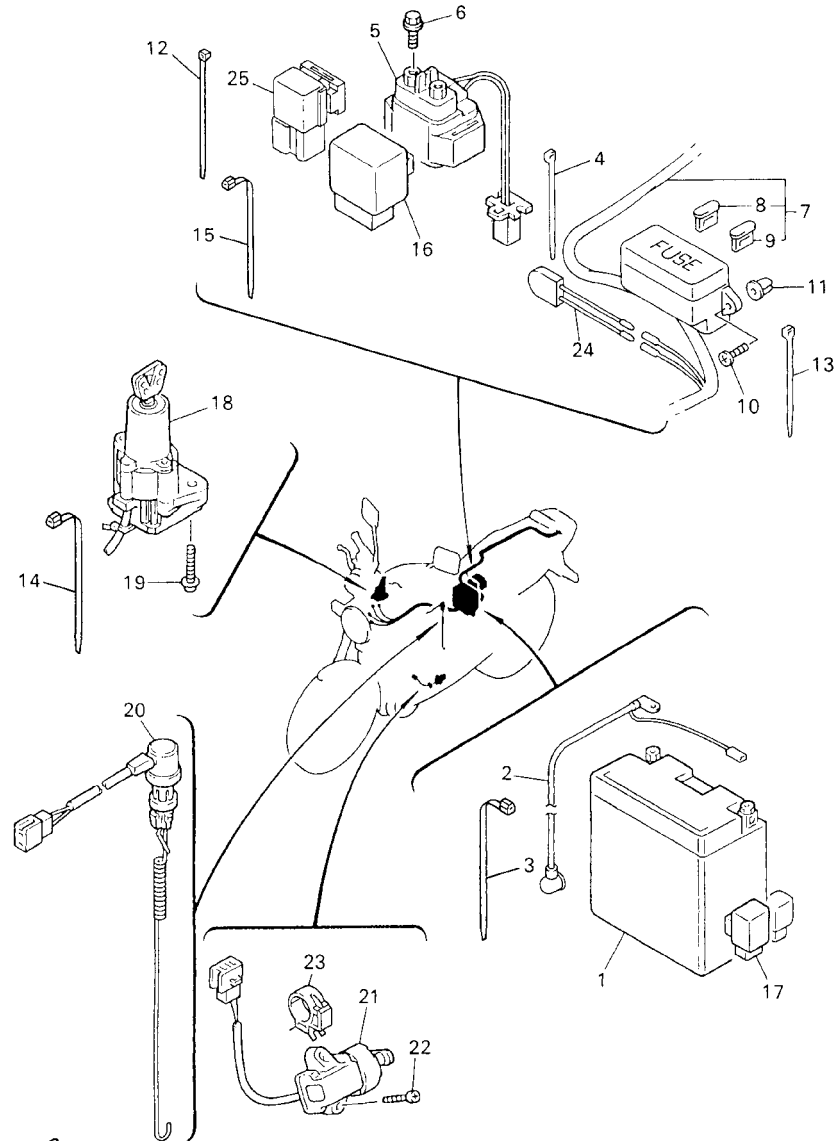

5EAT351-2460

REF. NO.	PART NO.	DESCRIPTION	5WM1	5WM3	5WM5	5WM6	REMARKS
1	5EA-82100-11	BATTERY ASSY (GS GT14B-4)	1	1	1	1	
2	5EA-82116-00	WIRE, MINUS LEAD	1	1	1	1	
3	90464-15195	CLAMP	1	1	1	1	
4	1UA-82591-00	BAND	1	1	1	1	
5	4KG-81940-00	STARTER RELAY ASSY	1	1	1	1	
6	95027-06008	BOLT, FLANGE	2	2	2	2	
7	5EA-82590-40	WIRE HARNESS ASSY	1	1			
	5EA-82590-50	WIRE HARNESS ASSY			1	1	
8	36Y-82151-00	.FUSE (15A-BL)	5	5	4	4	
9	5EA-82151-00	.FUSE (40A-BL)	2	2	2	2	
10	97707-60016	SCREW, TAPPING	2	2	2	2	
11	90338-08226	PLUG	2	2	2	2	
12	90464-16061	CLAMP	1	1	1	1	
13	1UA-82591-00	BAND	4	4	4	4	
14	90464-13073	CLAMP	1	1	1	1	
15	90464-13077	CLAMP	1	1	1	1	
16	5EA-81950-10	RELAY ASSY	1	1	1	1	
17	4BH-8195A-00	RELAY ASSY	1	1	1	1	
18	5EA-82501-00	MAIN SWITCH STEERING LOCK	1	1			
	4KG-82501-02	MAIN SWITCH STEERING LOCK			1	1	
19	90109-080G5	BOLT	2	2	2	2	
20	3YF-82530-01	STOP SWITCH ASSY	1	1	1	1	
21	3LD-82566-90	SWITCH, SIDE STAND	1	1	1	1	
22	90157-05008	SCREW, PAN HEAD	2	2	2	2	
23	90464-10190	CLAMP	1	1	1	1	
24	5FU-82560-10	THERMO SWITCH ASSY	1	1	1	1	
25	5DM-81950-00	RELAY ASSY	1	1	1	1	

NUMERICAL INDEX

PART NO.	GRID NO.	PART NO.	GRID NO.	PART NO.	GRID NO.	PART NO.	GRID NO.	PART NO.	GRID NO.	PART NO.	GRID NO.
5DM-W0041-50	E-8	2H7-11416-01	B-4	26H-12169-50	B-5	1HX-14131-00	B-15	4KG-14621-00	C-3	36Y-15336-02	C-6
4BP-W0042-50	E-12	2H7-11416-11	B-4	26H-12169-70	B-5	35H-14139-00	C-2	4KG-14631-00	C-3	1TX-15346-00	C-8
4SV-W0045-00	E-3	2H7-11416-21	B-4	26H-12169-90	B-5	3G2-1414A-72	B-14	4G0-14638-00	C-3	2H7-15361-00	C-8
5LV-W0046-50	E-6	2H7-11416-31	B-4	5EA-12171-00	B-7	5DM-14141-40	B-14	4KG-14641-00	C-3	2H7-15363-00	C-7
3GM-W0047-10	E-3	2H7-11416-41	B-4	36Y-12176-00	B-7	4KM-14142-15	B-14	5EA-14711-20	C-3	1TX-15365-00	C-5
3MA-W0047-10	E-3	4FM-11456-00	C-9	36Y-12178-10	B-2	830-14143-28	B-14	3XW-14714-00	C-3	1TX-15367-00	C-8
5EA-W0047-50	E-6	36Y-11474-00	C-9	5EA-12181-00	B-7	354-14147-00	B-15	4KM-14714-01	B-13	4CR-15374-00	C-8
1J3-W0048-00	E-3	5EA-11603-00	B-4	36Y-12193-10	B-2	36Y-14147-00	B-15	5EA-14721-20	C-3	1UF-15379-00	D-14
	E-6	5EA-11631-10	B-4	4KG-12210-00	B-7	5EA-14148-00	B-15	36Y-14747-00	C-3	36Y-15383-01	C-5
36Y-W0048-00	C-11	30X-11633-03	B-4	4FM-12213-00	B-7	5EA-14167-00	B-15	3XW-14755-00	C-3	36Y-15389-09	B-4
4SV-W0057-00	E-3	5EA-11650-00	B-4	4KG-12222-00	B-7	127-14186-00	B-14	5EA-1479H-01	B-13	5EA-15411-10	C-7
4SV-W0057-10	E-3	36Y-11654-00	B-4	5EA-12241-00	B-7	4KP-14191-00	B-15	5EA-15411-20	C-7	5EA-15411-20	C-7
5EA-W0057-50	E-6	36Y-11656-00	B-4	36Y-12251-00	B-7	4KM-14194-00	B-15	5EA-1479K-00	B-13	36Y-15412-00	C-5
26H-W0098-00	C-11	36Y-11656-10	B-4	36Y-12252-03	B-7	4SV-14197-00	C-2	4KG-14791-00	C-3	5EA-15416-10	C-7
3GM-W0099-00	E-9	36Y-11656-20	B-4	4KG-13151-00	B-9	4KM-14216-00	B-15	5EA-14803-10	B-13	5EA-15416-20	C-7
3XW-W1543-02	C-7	36Y-11656-30	B-4	4KG-13152-01	B-9	3G2-1423A-61	B-14	5EA-14872-00	B-13	36Y-15417-10	C-8
5EA-W1543-00	C-7	36Y-12111-00	B-5	4KG-13159-00	B-9	5EA-14261-10	B-14	5EA-14873-00	B-13	5EA-15426-10	C-7
4KG-W1741-00	C-12	4KG-12113-00	B-5	3CV-13300-00	B-8	4KG-14285-00	B-15	5EA-14881-00	B-13	5EA-15426-20	C-7
4HM-W2585-01	E-8	36Y-12114-00	B-5	36Y-13324-00	B-8	5EA-14294-00	B-12	5EA-14882-00	B-13	5EA-15427-00	C-7
	E-9	26H-12116-00	B-5	36Y-13325-00	B-8	5EA-14295-00	B-12	5EA-14883-00	B-13	36Y-15449-00	C-8
5DM-W2587-01	E-8	30X-12117-00	B-5	36Y-13340-00	B-10	4NK-14327-00	B-15	5EA-14885-00	B-13	4KG-15449-00	C-7
4KG-W2645-01	E-9	30X-12118-00	B-5	4H7-13411-02	B-10	5EA-14348-00	B-12	5EA-1490J-10	B-14	5EA-15451-00	C-7
5EA-Y2165-N0-4B	D-4	51Y-12119-00	B-5	36Y-13412-00	B-10	5EA-14349-00	C-2	3EN-1490K-00	C-2	4CR-15461-01	C-8
5EA-Y2165-P0-4B	D-4	36Y-12121-00	B-5	4CR-13414-00	B-10	5EA-14389-00	B-15	5EA-14900-30	B-14	4CR-15467-00	C-7
5EA-Y2165-R0-4B	D-4	26H-12153-01	B-6	4CR-13415-00	B-10	5EA-14401-00	B-11	5EA-14901-30	B-14	4KG-15481-01	C-7
5EA-Y2171-30-2X	D-7	26H-12153-09	B-6	36Y-13417-02	B-10	5EA-14412-00	B-11	5EA-14902-30	B-14	5EA-15481-00	C-7
5EA-Y2172-30-2X	D-7	26H-12168-A0	B-5	36Y-13441-00	B-10	31A-14419-00	B-11	5EA-14903-30	B-14	5EA-15484-00	C-6
5EA-Y2410-G0-X2	D-13	26H-12168-F0	B-5	4KG-13447-00	B-10	5EA-1442G-00	B-11	5EA-14904-30	B-14	4H7-15486-00	C-8
5EA-Y2410-G0-08	D-13	26H-12168-H0	B-5	5EA-13447-00	B-10	5EA-1442H-00	B-12	5EA-14912-10	B-14	36Y-15512-01	C-9
5EA-Y2410-G0-09	D-13	26H-12168-K0	B-5	36Y-13454-00	C-9	5EA-14425-00	B-11	5EL-14918-00	B-14	4KG-15517-00	C-9
5EA-11101-10	B-2	26H-12168-M0	B-5	4HM-13463-00	B-9	5EA-14426-00	B-11	5EA-14933-00	B-14	36Y-15519-00	C-9
5EA-11101-20	B-2	26H-12168-R0	B-5	4KG-13464-10	B-9	1HX-1443E-00	B-11	4SV-14935-00	B-15	36Y-15521-01	C-9
5EA-1111G-00	B-2	26H-12168-U0	B-5	4KG-13465-10	B-9	31A-14435-00	B-11	5DM-14985-00	B-14	3CV-15522-00	C-9
3XW-1111J-00	C-4	26H-12168-W0	B-5	4KG-13470-10	B-9	4KG-14437-00	B-11	5EA-14987-00	B-15	4KG-15524-00	C-9
3XW-1112J-00	C-4	26H-12168-Y0	B-5	5EL-13474-00	B-11	4KG-14451-00	B-11	5EA-14987-10	C-2	2H7-15531-00	C-9
36Y-11133-10	B-2	26H-12168-00	B-5	25G-13490-00	B-10	5EA-14453-00	B-11	5EA-14991-00	B-14	4KM-15580-00	C-9
5EA-11161-00	B-2	26H-12168-20	B-5	36Y-13490-00	B-8	3LD-14462-00	B-11	5EA-14996-00	B-15	1TX-16150-01	C-10
4KG-11166-00	C-5	26H-12168-40	B-5	5EA-13542-00	B-13	5EA-14463-00	B-11	5EA-15100-00	C-4	36Y-16154-00	C-10
5EA-11181-10	B-2	26H-12168-60	B-5	5EA-13543-10	B-12	5DM-14561-00	B-15	5EA-15100-10	C-4	4H7-16155-01	C-9
4KG-11191-10	B-2	26H-12168-80	B-5	16G-13569-00	B-11	5EL-14561-00	B-14	36Y-15163-00	C-9	36Y-16181-00	C-10
5EA-11193-00	B-2	26H-12169-E0	B-6	5EA-13586-10	B-11	583-14561-00	B-14	4H7-15167-10	C-4	341-16321-13	C-10
214-11198-01	B-10	26H-12169-G0	B-6	5EA-13596-10	B-11	1FN-14565-00	B-14	36Y-15189-00	B-10	2H7-16325-00	C-10
5EA-11311-00	B-3	26H-12169-J0	B-6	5EA-13971-00	B-12	4WM-14565-00	C-2	4H7-15189-00	C-5	36Y-16331-00	C-10
5EA-11311-10	B-3	26H-12169-L0	B-6	5EA-13972-00	B-12	5DM-14565-00	B-15	4K0-15189-00	C-5	5JW-16334-00	C-10
5EA-11351-00	B-3	26H-12169-N0	B-6	5DM-14610A-00	B-14	4KG-14611-00	C-3	5EA-15316-00	C-7	36Y-16335-00	C-10
3XW-11363-01	C-4	26H-12169-T0	B-6	5EA-14103-00	B-15	4KG-14612-00	C-3	36Y-15317-00	C-6	36Y-16351-00	C-10
3XW-11364-01	C-4	26H-12169-10	B-5	5EA-14105-00	B-14	4BE-14613-00	C-3	5EA-15326-00	C-7	1TX-16352-00	C-10
36Y-11411-01	B-4	26H-12169-30	B-5	5EL-14107-23	B-14	4PU-14615-00	C-3	1TX-15333-00	C-8	4KG-16356-00	C-10

NUMERICAL INDEX

PART NO.	GRID NO.	PART NO.	GRID NO.	PART NO.	GRID NO.	PART NO.	GRID NO.	PART NO.	GRID NO.	PART NO.	GRID NO.
4KG-16357-00	C-10	4KG-21512-00	D-4	5EA-23121-00	D-10	5EA-24500-01	D-13	3LN-2585G-00	E-12	5EA-27420-00	E-10
36Y-16371-00	C-10	1A8-21518-00	D-4	4KM-23123-01	D-12	4X8-24512-00	D-13	2KF-25852-50	E-12	36Y-27424-00	E-11
36Y-16381-11	C-11	5EA-21611-00	D-4	5EB-23125-00	D-11	3XV-24523-00	D-13	360-25854-01	E-12	5EA-27430-01	E-10
5EA-16381-00	C-11	4HM-2162A-00	D-5	5EA-23126-30	D-11	55K-24524-00	D-13	4HM-25854-00	E-8	4DN-27431-01	E-10
36Y-16383-00	C-10	5EA-2163F-00	D-5	5EA-23131-00	D-10	3XV-24534-00	D-13		E-9	4KG-27432-00	E-12
36Y-16384-00	C-10	5EA-21631-00	D-15	5EA-23136-30	D-11	5EA-24560-00	B-12	2GU-25855-00	E-12	1HX-27437-00	E-11
2H7-16385-00	C-10	4G0-21639-00	D-4	5EA-23141-30	D-11	4HM-24602-00	D-13	4HM-25867-00	E-8	5EA-27440-01	E-11
3CV-17121-00	C-12	4KG-21639-00	D-5		D-12	5EA-2470F-20	D-15	4KG-25867-00	E-9	4DN-27441-01	E-11
1TX-17131-00	C-12	51Y-21639-00	D-7	4PU-23144-00	D-11	4HM-24728-00	D-15	5EA-25872-30	E-8	4KG-27442-02	E-10
4CC-17141-00	C-12	5WM-2165C-00	D-4		D-12	5EA-24730-20	D-15	5EA-25873-20	E-8	4KG-27443-02	E-10
1TX-17151-00	C-12	5WM-2165C-10	D-4	4PU-23145-01	D-11	4BP-24737-00	D-15	4FM-25876-01	E-13	4KG-27813-00	E-12
1TX-17211-00	C-12	5EA-21654-00	D-5	4V4-23146-L0	D-11	22W-24741-00	D-4	4KG-25876-01	E-8	5EA-28100-00	D-6
3CV-17221-00	C-12	5WM-21660-00	D-4	3GM-23149-00	D-11		D-15	4BH-25886-02	E-13	36F-28379-00	D-5
1TX-17231-00	C-12	5WM-21660-10	D-4		D-12	4KG-24773-00-4B	D-15	4KG-25887-01	E-8	5EA-2838N-00	D-2
5EA-17241-00	C-12	5EA-21664-00	D-5	3LR-23149-00	D-11	4KG-2478E-00	D-15	3FV-2589F-00	E-8	5EA-2838R-00	D-2
1TX-17251-00	C-12	2N4-21717-00	D-4		D-12	4BP-24780-00	D-15		E-9	4KG-81600-00	E-14
5EA-17421-00	C-12	21V-21717-00	D-7	4V4-23153-L0	D-11	4BP-24792-00	D-15	31A-25894-01	E-12	5EA-81600-00	E-14
5EA-17460-00	C-13	5EA-21717-00	D-7	509-23158-L0	D-11	5EA-25117-00	E-2	4KG-25895-00	E-12	4BH-81604-00	E-14
4KG-18101-01	C-15	5EA-2172A-10	D-7		D-12	4FM-25149-00	E-2	4SV-25919-00	E-3	4KM-81604-00	E-14
4KG-18111-00	C-15	5EA-2172F-10	D-7	5EA-23170-30	D-11	4SV-25168-00-33	E-2	5LV-25919-00	E-6	3FV-81619-00	E-14
2GH-18112-01	C-15	5EA-2173B-20	D-7	5EA-23171-30	D-11	4XV-25181-00	E-2	4XV-25924-00	E-3	4KG-81634-00	E-14
5EB-18113-00	C-15	5EA-21732-00	D-7	4YR-23173-00	D-11	4FM-25190-00	E-2	5LV-25924-00	E-6	36Y-81638-50	E-14
2GV-18115-00	C-15	5EA-21732-10	D-7		D-12	5EA-25338-00-33	E-4	3GM-25925-00	E-3	2KT-81642-50	E-14
4G0-18127-00	C-15	5EA-2174B-20	D-7	5EA-23174-30	D-10	5EA-25364-00	E-4		E-6	4BH-81643-00	E-14
5RT-18140-00	C-14	5EA-2174X-00	D-7	278-23181-50	D-11	4FM-25366-00	E-4	5EA-26111-10	E-7	4BH-81643-10	E-14
2H9-18154-00	C-15	5EA-2174Y-00	D-7		D-12	4FM-25371-10	E-4	5PS-26133-00	E-7	3FV-81645-00	E-14
3XW-18511-00	C-14	4KG-21778-00	D-4	4PU-2331G-00	D-12	4FM-25377-00	E-4	4YR-26240-01	E-7	4BH-81645-00	E-14
4KG-18512-00	C-14	5EA-21779-10	D-4	5EA-23340-30	D-12	4FM-25381-10	E-4	4YR-26241-01	E-7	4BH-81660-00	E-14
3XW-18513-00	C-14	5EA-22110-00	D-8	1W1-23416-00	D-10	5EA-25388-00	E-4	3HX-26246-00	E-7	5EA-81671-01	E-15
4BR-18531-00	C-14	3FV-22128-00	D-8	26H-23418-01	D-10	4XV-25389-00	E-4	3MA-26279-00	E-8	4KG-81673-00	E-15
5EA-18540-01	C-14	3GM-22141-01	D-8	4KG-23435-00	D-10	5MT-25398-00	E-2	4VR-26280-01	E-7	3AJ-81801-00	F-2
4UN-18542-00	C-14	5EA-22149-00	D-8	4H7-23441-00-38	D-10		E-4	4KG-26281-00	E-7	5GH-81815-00	F-2
36Y-18562-00	C-14	4KG-22151-00	D-8	5H0-23442-01-38	D-10	5MT-25398-10	E-2	3XW-26282-01	E-7	4XV-8182A-00	F-2
4UN-18566-00	C-14	5EA-2216F-00	D-9	3FV-23462-00	D-10		E-4	4VR-26290-01	E-7	3AJ-81826-00	F-2
5EA-21110-21-33	D-2	4HD-2218A-00	D-4	4X7-23469-10	E-7	5MT-25398-20	E-2	5EA-26302-10	E-7	11H-81844-00	F-2
5EA-21110-30-33	D-2	3FV-22184-00	D-8	5FY-2411B-00	D-13		E-4	5EA-26330-00	E-7	1FK-81847-00	F-2
4KG-21150-00-33	D-2	4BH-2219X-00	D-3	5FY-2411B-50	D-13	5EA-25439-00	E-4	3GM-26455-00	E-9	36Y-81890-00	F-2
5EA-2117E-00	D-4	5EA-22210-30	D-9	3YF-2414J-10	D-4	5DM-2580T-00	E-3	3GM-26464-00	E-9	5EA-81890-00	F-2
3YX-21308-00	D-15	5EA-22277-00	D-9	2YK-24181-10	D-13	5DM-2580U-00	E-3	4KG-26470-01	E-9	36Y-81910-50	E-14
4KG-21315-02	D-2	4KG-22311-00	D-8	5EA-24181-00	D-14	5EA-2580W-10	E-6	5EA-27111-10	E-10	4KG-81940-00	F-10
4KG-21331-00	D-5	4KG-22321-00	D-8	3Y6-24183-00	D-13	5EA-2581K-00	E-12	128-27114-00	E-10	4BH-8195A-00	F-10
4KG-21332-00	D-5	5EA-23102-30	D-11	4HM-24183-00	D-13	5JJ-2581T-10	E-3	4KG-27211-00	E-12	5DM-81950-00	F-10
4HM-2139X-00	D-4	5EA-23103-30	D-11	2GH-24184-00	D-13	5EA-25819-00	E-6	4BP-27222-01	E-12	5EA-81950-10	F-10
4KG-2140X-00	D-2	5EA-23110-30	D-11	12R-24186-00	D-13	4BP-2582A-00	E-12	5EA-27311-00	E-10	4BH-81970-00	E-14
4KG-2140Y-00	D-2	4PU-23111-20	D-11	5WM-24240-00	D-13	3GM-2582W-A0	E-6	4FM-27315-00	E-10	4BH-81972-00	E-14
4KG-21400-00	D-2		D-12	5WM-24240-10	D-13	4BP-2583V-01	E-12	5EA-27410-00	E-10	5EA-82100-11	F-10
4X7-2149Y-00	B-11	3YF-23118-00	D-11	5WM-24240-20	D-13	341-25846-00	E-2	4BP-27413-00	E-10	5EA-82116-00	F-10
4KG-21511-01-4B	D-4		D-12	5EL-24411-00	B-14	4BP-2585F-00	E-12		E-11	120-82131-00	D-5

NUMERICAL INDEX

PART NO.	GRID NO.	PART NO.	GRID NO.	PART NO.	GRID NO.	PART NO.	GRID NO.	PART NO.	GRID NO.	PART NO.	GRID NO.
4HM-82131-00	D-5	4PU-8353F-00	F-4	3YF-84751-00	F-8	90109-100G0	E-11	90179-25033	D-10	90269-06081	D-5
4WM-82131-00	D-5	4HM-8353L-00	F-4	4KM-85130-00	D-6	90109-101E6	E-10	90183-05061	D-5	90331-15039	C-9
36Y-82151-00	F-10	4HM-83532-20	F-4	4KG-85132-00	D-5	90109-103A9	E-11	90183-06053	D-5	90338-06233	D-7
5EA-82151-00	F-10	4HM-83532-30	F-4	5EA-85132-00	D-5	90109-104E6	E-10	90185-10037	E-10	90338-08163	D-10
5EA-82305-40	F-9	5EA-83540-20	F-4	5G2-85720-00	F-9	90110-05112	D-13	90185-10091	E-10		D-15
5EA-82310-10	F-9	1JK-83541-00	F-5	4HM-85750-00	F-4	90110-06004	C-7	90185-18104	D-8		E-12
4BR-82317-00	F-9	4KG-83550-02	F-5	4KG-85752-01	F-9	90110-08199	D-2	90185-24165	E-5	90338-08226	F-10
5EA-82320-10	F-9	4HM-83559-00	F-4	5G3-85753-00	F-9	90110-08231	D-2	90201-06380	F-8	90340-10108	B-7
3NS-82370-00	F-9	5EA-83570-60	F-4	5EA-85885-00	C-2	90110-08232	D-2	90201-08016	B-15	90340-14132	B-10
5UX-82370-00	F-9	5EA-83570-70	F-4	90101-08766	E-4	90116-10561	C-4	90201-08083	E-12	90387-060A7	B-9
4KG-82501-02	F-10	12R-83578-00	F-4	90105-060A0	C-8	90116-10562	C-4	90201-08366	C-4	90387-064H8	E-11
5EA-82501-00	F-10	5FU-83790-00	B-15			90116-10563	C-4	90201-08382	B-3	90387-064M9	B-9
4KG-82509-00	F-9	5FU-83790-10	B-15	90105-060A1	C-5	90116-10575	E-4	90201-10118	B-7	90387-06676	F-5
3YF-82530-01	F-10	5EA-83912-00	E-9	90105-060A2	C-5	90119-05071	F-9		E-8	90387-07674	F-8
1L9-82540-00	F-9	5EB-83922-01	E-8	90105-06305	B-2	90149-05110	B-10		E-9	90387-0804N	F-6
5EA-82541-00	C-2	437-83936-01	E-9	90105-06424	B-7	90149-05321	C-14		E-13	90387-1003V	D-2
5FU-82560-10	F-10	4PU-83963-00	E-7	90105-065A9	C-5		F-9	90201-10128	B-2	90387-1003W	D-2
3LD-82566-90	F-10	5EA-83969-10	E-7	90105-066A0	C-11	90149-06006	D-15	90201-102G9	B-2	90387-1005B	E-9
5EA-82590-40	F-10	4UW-83972-00	E-7	90105-06790	C-8	90149-06008	D-13	90201-102M1	B-8	90387-10636	E-11
5EA-82590-50	F-10	4HM-83975-11	E-7	90105-06792	C-7	90149-06228	C-9	90201-10669	E-11	90387-114K8	C-15
1UA-82591-00	D-14	3GM-83980-00	E-9			90149-06298	D-7	90201-12575	C-15	90387-201L2	C-9
	E-7	4HM-83980-00	E-8	90105-06798	C-7	90150-06036	D-4	90201-12588	C-15	90387-220R2	C-12
	F-10	4KG-84154-00	F-6	90105-06799	C-8	90151-06025	C-5	90201-186M4	D-8	90387-2200T	E-2
3MA-82591-00	D-13	2F9-84314-00	F-6	90105-07342	B-7	90153-06029	B-2	90201-203F0	D-8	90387-22660	E-9
4PU-83310-00	F-3	4KG-84315-00	F-6	90105-080A3	C-4	90154-05059	D-5	90201-21608	B-10	90387-250R3	C-13
306-83311-40	F-3	4KG-84318-00	F-6	90105-083A9	E-4	90154-05073	C-7	90201-220T0	D-10	90387-28001	E-5
4PU-83320-00	F-3	4KG-84320-00	F-6	90105-084A1	E-14	90154-05079	C-7	90201-226H9	C-12	90387-2805W	E-5
4PU-83330-00	F-3	4PU-84320-00	F-6	90105-084A9	E-14	90157-02031	F-4	90201-257H0	C-12	90387-284K1	C-10
1VU-83332-00	F-3	5EA-84320-00	F-6	90105-08776	E-14	90157-05008	F-10	90201-257R5	E-5	90387-300R4	C-13
51L-83332-01	F-3	4KG-84326-00	F-6	90105-100A4	C-4	90157-05079	E-10	90201-286H8	C-10	90387-3003P	C-12
4PU-83340-00	F-3	4KG-8433E-00	F-6	90105-10300	D-2		E-11	90201-307H1	C-12	90387-350R5	C-13
1VU-83342-00	F-3	4KG-84330-00	F-6	90105-10313	D-2	90157-05095	C-8	90202-05193	D-13	90401-10159	E-8
51L-83342-01	F-3	4KG-84331-00	F-6	90105-10323	D-2	90159-03102	F-4	90202-06113	D-5		E-9
3GM-83350-01	F-9	4KG-84332-00	F-6	90105-10402	D-2	90159-06056	E-12	90202-24190	D-10		E-13
18G-83365-00	F-3	5G2-84333-00	F-6	90105-10445	E-15	90159-06058	D-2	90202-26142	D-10	90401-10160	E-8
4KG-83371-20	F-9	4KG-84334-00	F-6	90105-105A0	E-6	90159-06107	E-15	90206-17084	E-11		E-9
4KG-83371-30	F-9	47J-84334-00	F-6	90105-105A7	E-3	90167-04057	F-4	90209-06096	C-8	90413-11025	B-12
4HM-83506-00	F-4	4KG-84335-00	F-6	90105-10609	D-2	90170-06228	C-15	90209-06174	B-9	90430-05126	B-10
4HM-83507-00	F-4	4KG-84344-00	F-6	90105-12425	D-2	90170-08010	E-12	90209-25196	C-12	90430-06014	B-2
4HM-83508-00	F-4	4PU-84346-00	F-6	90109-063F1	D-5	90170-20323	C-10	90209-27192	C-12		B-10
4KG-83509-00	F-5	4E2-84347-00	F-6	90109-063F7	C-14	90176-06055	D-10	90209-32231	C-12	90430-14240	B-3
1YT-83517-00	F-5	4KG-84365-00	F-6	90109-063G3	C-11	90176-10078	B-2	90215-25218	C-10	90445-105K7	D-13
2GV-83517-00	F-5	4KG-84366-00	F-6	90109-066F0	B-2	90176-22081	D-10	90215-30233	C-13	90445-115K8	B-11
4R0-83517-00	F-5	4KG-84367-00	F-6	90109-080G5	F-10	90179-06635	D-15	90240-08124	E-12	90445-170K9	E-10
4KG-83519-00	F-4	4KG-84397-00	F-6	90109-081G0	E-11	90179-08327	B-4	90249-04184	B-7	90450-63002	B-11
4PU-83520-00	F-5	5EA-84710-10	F-8	90109-082A4	E-10	90179-10247	D-2	90267-40076	D-5	90450-64001	B-11
1E6-83524-60	F-4	36Y-84714-40	F-8	90109-083G4	E-3	90179-10658	D-2		D-6	90461-10132	E-8
5EA-8353E-20	F-4	4HM-84735-00	F-8		E-6	90179-22063	C-13	90267-40090	D-8	90464-10190	E-9

NUMERICAL INDEX

PART NO.	GRID NO.	PART NO.	GRID NO.	PART NO.	GRID NO.	PART NO.	GRID NO.	PART NO.	GRID NO.	PART NO.	GRID NO.
90464-10190	F- 10	90506-40529	E- 10	93106-35042	E- 4	93900-00030	E- 2	95707-06500	D- 15	97080-06008	C- 3
90464-12036	D- 5	90508-233B5	C- 14	93106-40041	E- 4				F- 5	97080-06070	F- 9
90464-13073	F- 9	90508-32682	C- 15	93109-08061	C- 10	94112-17034	E- 2		F- 8	97701-40620	F- 3
	F- 10	90560-28389	E- 4	93109-12075	C- 15	94118-17027	E- 4		F- 9	97707-40014	F- 4
90464-13077	F- 3	91314-08020	E- 12	93210-06422	C- 11	94582-05112	E- 4	95707-08500	F- 7	97707-40030	F- 4
	F- 9	91314-08030	D- 10	93210-07135	C- 4	94591-05156	B- 7	95707-12500	F- 3	97707-40516	F- 4
	F- 10	91314-08040	D- 12	93210-10096	B- 10	94701-00241	B- 2	95807-06012	F- 9	97707-50125	B- 11
90464-15157	D- 5	91316-06020	E- 8	93210-13657	B- 8	95024-06010	D- 8	95807-06016	B- 12	97707-60016	F- 10
90464-15192	E- 9		E- 9		B- 9	95024-06020	C- 8		D- 5	97890-05008	B- 15
90464-15195	F- 10	91317-05010	D- 13	93210-15566	B- 8	95024-06025	C- 8	95807-06025	D- 8	98501-05018	E- 14
90464-16039	F- 9	91317-05035	E- 7	93210-16325	B- 9			95807-10040	C- 3	98502-04012	E- 8
90464-16061	D- 7	91317-06010	C- 6		B- 10			95814-06030	C- 5	98502-05008	C- 2
	D- 15	91317-06020	B- 9	93210-207A0	C- 5	95024-06035	C- 8	95814-06040	C- 5	98507-03010	F- 4
	E- 7		B- 10	93210-26658	B- 8	95024-06040	C- 7	95814-06050	C- 5	98507-04008	B- 14
	E- 9		B- 11	93210-27370	C- 8			95814-06055	C- 5		B- 15
	F- 10	91317-06025	B- 7	93210-29196	F- 9	95024-06050	C- 7	95814-06065	C- 5	98507-04030	F- 4
90465-08252	C- 6		B- 10	93210-30660	C- 12	95024-08040	F- 7	95814-06070	C- 5	98507-05014	B- 15
90465-08253	C- 6	91317-06035	B- 10	93210-40659	B- 11	95024-10045	D- 9	95814-08025	C- 3	98507-05016	F- 6
90465-10027	C- 5	91317-06040	B- 9	93210-47440	C- 9	95027-06008	F- 10	95814-08045	C- 4	98507-05022	E- 7
90465-10098	F- 9	91317-08025	D- 12	93210-87723	B- 10	95027-06010	E- 8	95814-08055	C- 4	98507-05025	E- 7
90467-08075	B- 12		D- 15	93305-20605	C- 12			95814-08065	E- 14	98507-05045	E- 7
90467-08092	B- 13	91401-20012	E- 11	93306-00008	C- 12	95027-06014	B- 13	95814-08100	C- 4	98580-04010	B- 15
90467-09006	D- 14		E- 12	93306-00304	C- 10	95027-06016	F- 8	95814-10050	C- 4	98580-05018	B- 14
90467-10039	B- 11	91701-06042	E- 11	93306-00401	C- 9			95814-10060	C- 4	98606-04012	D- 13
90467-11106	B- 11	91808-16023	B- 2	93306-00420	E- 2	95027-06020	D- 10	95817-06030	C- 5	98706-04012	E- 8
90467-12052	B- 12	92014-06012	B- 9	93306-07806	E- 4	95027-06025	E- 8	95817-06040	C- 4		E- 9
90467-13042	B- 12	92901-05100	E- 14	93306-20545	C- 9	95304-06700	C- 15		C- 5	98706-04016	E- 9
90467-14015	C- 5	92901-05600	E- 14	93306-20561	C- 13	95307-05600	F- 5	95817-06055	C- 5	98707-04008	B- 15
90467-14057	E- 12	92902-04100	E- 8	93306-20644	E- 4	95307-08600	E- 4	95817-06070	C- 5	98707-05010	B- 15
90467-14150	B- 13	92902-04600	E- 8	93306-30434	C- 12	95317-06600	B- 3	95817-06080	B- 8	98707-06016	C- 14
90467-14193	B- 12	92902-06100	F- 6	93310-350M3	C- 10			95817-06095	C- 4	98907-06012	F- 9
90467-15012	B- 13	92904-08600	C- 3	93315-23607	B- 8	95317-08600	B- 3	95817-06110	C- 4	99001-10600	C- 15
90468-08104	B- 13	92907-03100	F- 4	93315-42523	D- 8	95604-08100	E- 12	95817-06125	C- 5	99009-62500	C- 9
90480-01558	D- 7	92907-04100	F- 4	93317-21288	C- 7	95604-08200	C- 3	95817-08012	D- 4	99247-00080	D- 4
90480-13369	D- 4	92907-04600	F- 4	93317-42060	C- 6	95606-06100	E- 8	95817-08045	C- 4	99530-08016	B- 10
90480-13398	D- 4	92907-05600	C- 5	93399-99931	D- 10	95607-06100	F- 8	95817-08055	C- 4		C- 7
90480-13567	D- 2		F- 6	93399-99932	D- 10	95607-08200	D- 2	95817-10060	C- 4	99530-10114	C- 8
90480-15235	B- 9	92907-06200	B- 9	93440-09139	B- 8			95824-06020	C- 15	99530-10116	C- 7
90480-16284	B- 9	92907-06600	B- 3	93440-28062	C- 12	95607-10200	D- 9	95827-06020	B- 9	99530-12016	C- 4
90480-18276	F- 8		C- 6	93440-30077	C- 12			97007-05010	C- 5	99530-14016	B- 3
90501-06022	C- 14	92907-08600	C- 3	93440-34025	C- 12			97007-06012	C- 8		C- 4
90501-15001	E- 11	92907-10200	D- 2	93440-52118	C- 13	95617-06625	B- 2		E- 12		
90501-153A2	B- 7	92990-06600	C- 3	93440-62032	C- 13	95617-06635	B- 2	97007-08030	D- 13		
90501-20422	B- 10	93102-12106	C- 15	93450-19052	B- 4	95617-08625	B- 2	97017-08025	C- 3		
90506-18168	E- 10	93102-25253	C- 9	93501-04011	E- 11	95627-08330	B- 3	97024-08025	C- 3		
90506-20377	E- 12	93102-40330	C- 12	93511-32017	C- 10	95702-05500	E- 14	97027-06012	C- 9		
90506-23528	E- 10	93105-45017	E- 2	93604-08071	E- 15	95706-06500	E- 9	97027-06016	C- 9		
90506-26225	E- 10	93106-28043	E- 2	93626-08210	B- 8	95707-05500	D- 6		C- 10		

CONTENTS

ENGINE

CYLINDER HEAD	B2
CYLINDER	B3
CRANKSHAFT. PISTON	B4
VALVE	B5
CAMSHAFT. CHAIN	B7
OIL PUMP	B8
OIL COOLER	B9
OIL CLEANER	B10
INTAKE	B11
AIR INDUCTION SYSTEM	B13
CARBURETOR	B14
EXHAUST	C3
CRANKCASE	C4
CRANKCASE COVER 1	C7
STARTER	C9
CLUTCH	C10
TRANSMISSION	C12
SHIFT CAM. FORK	C14
SHIFT SHAFT	C15

CHASSIS

FRAME	D2
FENDER	D4
SIDE COVER	D7
REAR ARM. SUSPENSION	D8
REAR SUSPENSION	D9
STEERING	D10
FRONT FORK	D11
FUEL TANK	D13
SEAT	D15
FRONT WHEEL	E2
FRONT BRAKE CALIPER	E3

REAR WHEEL	E4
REAR BRAKE CALIPER	E6
STEERING HANDLE. CABLE	E7
FRONT MASTER CYLINDER	E8
FRONT MASTER CYLINDER 2	E9
STAND. FOOTREST	E10
REAR MASTER CYLINDER	E12
GENERATOR	E14
PICK UP COIL. GOVERNOR	E15
STARTING MOTOR	F2
FLASHER LIGHT	F3
METER	F4
HEADLIGHT	F6
TAILLIGHT	F8
ELECTRICAL 1	F9
ELECTRICAL 2	F10

INDEX

NUMERICAL INDEX	M1
-----------------------	----